

DTMF-16c

Touchtone[®] Decoder

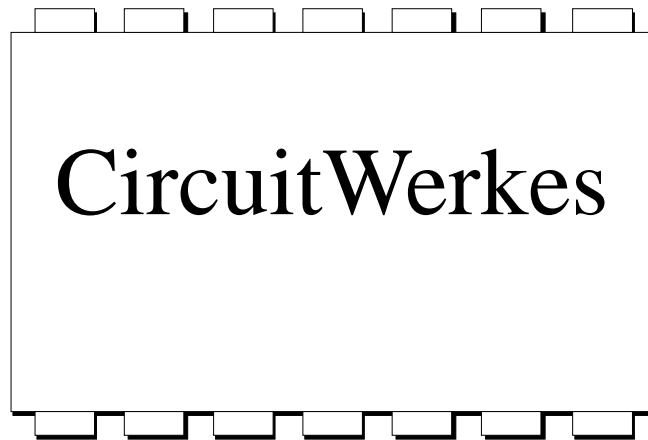

Technical Manual

CircuitWerkes

2805 NW 6th Street · Gainesville, FL 32609

(352) 335-6555 · Fax (352) 380-0230

<http://www.circuitwerkes.com>

© 1992-2003 CircuitWerkes All Rights Reserved. All information contained within is proprietary.
No part of this manual may be reproduced or copied without the express written consent of CircuitWerkes.

Touchtone[®] is a registered trademark of AT&T.

Description

The CircuitWerkes DTMF-16 is an integrated Touch Tone detector and sixteen output decoder, offering an optoisolated Darlington output for each of the sixteen standard DTMF tones. Separate emitters and collectors are available for each of the twelve "common" DTMF tones, 1-9, 0, *, and #. Separate Collectors and a common emitter are brought out for DTMF Tones A, B, C, and D. The open collector Darlington outputs provide 5000 volts of isolation and are capable of sinking up to 150mA continuously (emitter-collector voltage should not exceed 30 volts). These outputs along with 12 volts DC (unregulated), and various internal test and interface signals are available at the unit's D-SUB 37 pin connector. When interfacing the DTMF-16's outputs to low Voltage dc lines such as computer inputs, etc the optocouplers provide greater isolation and do not contain mechanical parts to wear out as with relays. It is **not** normally necessary or suggested to use external relays unless you are planning to switch AC Voltages or audio signals. Correct polarity must be observed for the optocouplers to work.

Installation & Operation

Setup

The DTMF-16 comes from the factory ready to use, just hook up an audio source to the tip and ring (the sleeve is left floating) on the DTMF-16's 1/4" audio input jack, connect your equipment to the supplied DB37 male connector, plug in the power supply and it's ready. Typical hookup diagrams are supplied in the schematics section at the end of this manual. The DTMF-16 has several user configurable options that are set via internal jumpers.

The Mode jumper (J1) when "OPEN" selects momentary decoder operation. The momentary output is activated only for the duration of the incoming DTMF tone. When the mode jumper is closed the decoder is in (interlocked) latching mode. When in latching mode the selected output remains activated until another output is selected. The second jumper (J2) enables the acknowledge beep when installed. The acknowledge beep is fed back down the audio line & and is intended to provide an audible signal to the operator when the DTMF-16 is used in conjunction with a telephone coupler to make a remote control. The beep jumper is normally shipped in the open (off) mode when the DTMF-16 operates by itself .

The filter mode selectors allow you to configure your DTMF-16 for two alternate momentary modes. In the "norm" position, the decoder provides quick detection of DTMF tones. If you are using the interlocked latching mode, the jumper must be in the "norm" position. One of the most common trouble calls that we get is from users who have gotten a decoder with the filter jumper (J3) set to either position 2 or 3. ***If you're having trouble with your unit, check J3's position first.***

When set to the 2T position, the two tone sequence decoder is selected. In this mode, a specific "attention" tone must be sent before each command. For instance, if the * key is selected as the attention tone and you wanted to activate the number 1 output you would send { *1 } to the decoder. You can select any of the 16 standard DTMF tones to act as the attention signal by placing a jumper on the appropriate pins of the 2x16 jumpers (J4) located between U3-6 and U2. The two tone mode provides three possible advantages over the normal fast mode. First, it improves reliability by preventing false tripping from transient audio passages. Second, it allows you to add up to 15 decoders to an audio line, each using separate attention tones. Lastly, the two-tone mode provides a slight level of security when used with telephone couplers. The two-tone mode can not be used if the DTMF-16 is in the interlocked latching mode. ***Do not jumper more than one tone at a time.*** While that usually won't damage anything, the decoder also won't work properly, if at all. The second alternate mode delays detection of the DTMF tones for a fraction of a second. The delay prevents the decoder from detecting transient audio passages

containing valid DTMF frequencies from being decoded. This anti-falsing delay provides reliable detection of single DTMF tones that last for at least 1/2 second. Several satellite news/sports networks use long DTMF tones for signalling affiliate breaks and cues. Neither filter mode is compatible with the latching output mode because the filters disable the outputs after a few seconds.

The remaining four jumpers, labelled A-D hex data, are simply in the paths of the TTL level hexadecimal data outputs of the decoder; they are normally installed in the open position at the factory. In the closed position, the hex outputs appear on the D-37F output connector. If needed, the jumpers can be removed and the corresponding four pins of the D-37F output connector can be accessed via the jumper/header pins for other purposes. For example, special ComboLok options can be interfaced to the outside through these pins.

Mounting

The basic DTMF-16 can be either desk or wall mounted. Keyhole cutouts on the ears of the enclosure are provided for wall mounting. Two optional rack mounts, the RM-01 and RM-02 are also available for those who would like to mount one or two DTMF-16s in a 19 inch rack cabinet.

Basic Operation

The DTMF-16 requires no operator intervention. It monitors an audio source until a valid DTMF tone or combination sequence occurs, then energizes the tone's corresponding (Darlington output) optocoupler. The resulting open collector output appears on the unit's db37 connector.

Connections

The power connection is made via 2.1 mm coaxial jack and will accept from 8 to 18 Vac. A power supply is provided with each DTMF-16; however, if you wish to supply your own, it must be able to provide at least 150ma.

The DTMF-16's audio connection is made via the 1/4 inch jack located next to the power connector. The connector is a tip, ring & sleeve type with the tip & ring making the audio path. The audio input is an unbalanced input with an input impedance of approximately 10kOhms.

Audio input level should be between 0.1 and 5 volts peak to peak

Each DTMF digit is assigned to an optocoupler. For the 12 standard tones, each optocoupler's emitter & collector is available at the D37f connector. The emitters of tones A-D share a common output pin. When a tone is detected, the resistance of the optocoupler drops to a few ohms which emulates a contact closure for most dc applications. Most low or medium powered switching can be done directly from the optocouplers. Computer or logic inputs can also be directly driven from the optocoupler outputs. For higher Voltage/higher current loads, the optocouplers can drive most external relays. A sample hookup diagram of a computer/logic connection and a relay connection can be found on page 9 of this manual. ***The optocouplers are polarity sensitive and will conduct in one direction only, so the emitter should always be closer to negative (or ground) than the collector.*** As with relay closures, the individual optocouplers may be tied together in parallel if desired.

Care & Feeding

Generally, the DTMF-16 may be placed anywhere other electrical equipment is in operation. As always, it is best to avoid extreme temperatures, immersion, or high impacts.

If you wish to clean the outside of the DTMF-16, use a damp cloth soaked in a mild soap and water solution. Detergents, alcohol, or solvents may remove the screen printing or mar the case.

Theory of operation

Input audio is capacitor coupled to the Motorola 145436 low power DTMF receiver. The MC145436 requires only one resistor and one crystal for frequency reference. The hexadecimal coded output is decoded by the CMOS 4514 4 to 16 line decoder. The hex-coded BCD data is connected directly to the 4514 decoder; but the data valid (strobe) pulse from the MC145436 drives the bases of two npn switching transistors, q1 and q2. q2's sole purpose in life is to be an inverter/buffer of the DV pulse for the accessory header (2x4 pin header) located beside the 4514 chip and the DV LED. Q1, more importantly, pulls up the Follow pin (pin 1 a.k.a. strobe) on the 4514 and turns on transistor q3 during the DV pulse. When q3 is thus energized, it pulls the INHibit pin (pin 23) of the 4514 low, enabling the chip to place a high on the output selected by the MC145436's hex-coded BCD data. The high going outputs of the 4514 drive optocouplers u3 through u6. Diodes d2 and d3 connect the base of q4 and q3 to the enable/disable pin of the 2 by 5 header and the disable pin of the d37f connector. When either pin is grounded, the decoder is disabled.

Q1's high-going (trailing) edge triggers the DTMF acknowledge beep circuit. After Q1 turns off, r8 pulls the the line low through Q5. Q5 is a gate controlled by Q4 so that no beeps occur until the second tone of a 2-tone sequence or if the unit is disabled by the combination lock option. The 4093's pin 1 (u7a) goes low for a short period of time (determined by c9 and r12) after q1's high-going edge occurs which gates the oscillator (formed by u7d, u7c, c8, r10, and r11) for the duration of the pulse. The resulting short burst of midrange square waves is cap coupled to the audio input via jumper J2 so that any valid DTMF tones is followed by a brief acknowledge beep. If the DTMF-16 is not being used in a situation where a confirmation that the DTMF tone was decoded is desired, jumper J2 or J2b can be pulled to disable the beep.

When the decoder is set (via jumper 1) to interlocked latching mode, the base of transistor q3 is held high which pulls the INHibit pin of the 4514 low, keeping the last-selected output activated until a new DV pulse (accompanied by new BCD data) occurs. Diode d1 prevents Vcc through r9 from flowing back through the buffered DV circuit when J1 is on.

The filter select jumper allows the user to select between normal operations, a two tone sequence decoder or an anti-falsing delay filter. When the filter select jumper, J-3, is set to the normal mode (position 1), transistor q4 is always on, enabling the outputs. Q4's primary function is to turn the outputs off when J3 is set to either of the two filter modes until the appropriate signals or timing have occurred. Q4 controls the operation of all optocouplers by sinking the cathode buss to ground. When J3 is set to the 2T mode (position 2), the high going output of the 4514 chip must be sent via the tone select jumper (J4) to c11, a .1uF capacitor. C11 charges during the output pulse, but then suddenly discharges at the end of the pulse pulling u7b's input momentarily low. U7b inverts the signal and causes u8's output to drop low, quickly discharging c12 via d6 & r19. When c12 is discharged, u8c goes high, turning on q4 & enabling the optocouplers.. Q4 remains on for a few seconds while c12 slowly charges via r18. When the filter select jumper is set to AF (position 3), buffered high going DV from q1 is fed to the inputs of u8a causing its output to go low, slowly discharging c7 through r20. When c7 is discharged, the output of u8d goes high enabling the optocouplers through q4.

The 4514 directly drives the 16 darlington optocouplers to saturation. The Optocouplers are quad packaged for higher density board designs. A PC Board silk screen legend shows which optocouplers are associated with their tones. An onboard 5 volt regulated supply easily handles the circuit's power needs.

Trouble Shooting

- Problem:** No outputs function and there is no BCD data on pins 1, 2, 13, or 14 of the 145436. No DV LED.
- Solution:** Power supply failure (check bridge first), improper audio input (check the audio input jack to see if it's making proper contact with your plug. Sometimes the jack's pins get bent out of place when plugging in.), bad MC145436 or damaged crystal
- Problem:** DTMF-16 outputs test good but won't activate my equipment.
- Solution:** Polarities may be reversed. Optocouplers will conduct in one direction only. In some computer related cases, a different version of the DTMF-16 output chip may be required, replacements are available free from the factory. Adding an external relay can also solve this problem.
- Problem:** One or more outputs do not operate with an incoming tone. Beep & DV LED work.
- Cause:** Failed optocoupler(s), failed 4514, bad, q3 or d1 zotched. Is J3 in the right position for your situation? Try setting it to the normal mode (pos. 1). Distorted DTMF tone.
- Problem:** No outputs will operate with an incoming tone, no beep. DV LED works.
- Cause:** Q1 is fried.
- Problem:** None of the outputs function with incoming tones; 4514 outputs go high (approx 1-2 V) during appropriate tones. DV LED lights during tones.
- Cause:** Incorrectly wired output connector, bad q4 or r14 open - missing, improperly placed or missing filter select jumper.
- Problem:** None of the outputs function with incoming tones; BCD data (during incoming tone) good at pins 1, 18, 17, 16 of the but, no output of 4514.
- Cause:** Incorrectly wired output connector (pin 1 grounded), bad 4514, bad q1, q3 or r3/r4 open, missing.
- Problem:** No beep. Outputs functioning properly on db37.
- Cause:** 4093 failed Q5 blown or "beep" jumper removed.

The DTMF-16c has a red LED marked DV that should light whenever a tone is detected. If you have problems, check that LED for operation during a tone. If it's not operating, then there's an audio input problem with input jack/plug or your wiring or the MC145436 chip/ associated circuit is bad. If you have an amplified speaker, listen to your source audio at the jack's wiring connector to verify that the audio is getting that far. If the light does come on, then hook up your external connectors in the normal way that they will be used and, using a D.C. Voltmeter (preferably analog), look at the two pins associated with the tone that you are using. When there is no tone, you should see Voltage from whatever source you're trying to switch. Verify that the collector pin is high and that the emitter is low. If they are reversed, the unit will not work. If there's no Voltage from your source, then either your source is bad or your wiring is faulty. If there is Voltage, then verify that it's not more than 30 Volts and wait for a tone. During the tone, the Voltage should fall to nearly zero. If it does, then the decoder is working. If not, then there is a problem with the 4514 chip, an output chip or an internal jumper such as J3. If you suspect an output chip, there are 4 identical chips, each containing 4 optocouplers. You can swap them around to test any particular output.

Note: Excessive current or Voltage through the emitter collector junction of the NEC optocouplers will destroy them.



Circuitwerkes DTMF16

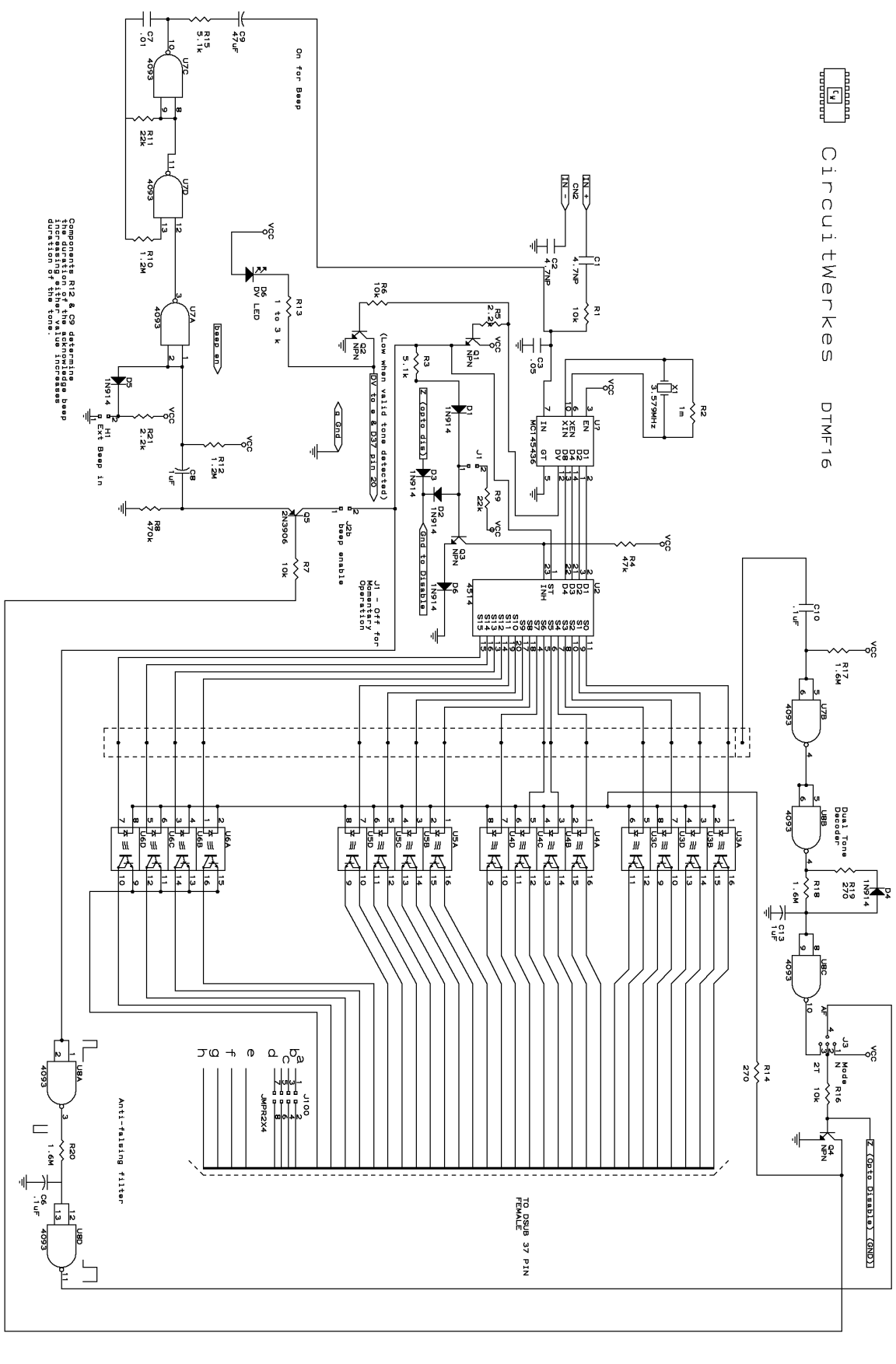

Power Plane: U1=5, U2=24, U7=814
 Q1-4 are 2M4401 or equiv.
 Capacitor c4 (.01uF) deleted
 Capacitor c11 not used
 U3, U4, U5, & U6 = NEC 2502 or 2501

Component R12 & C9 determine
 the duration of the acknowledge beep
 duration of the tone increases
 duration of the tone

Anti-ringing filter

TO DSUB 37 PIN
 FEMALE

Examples of typical optocoupler usage

Optocoupler used as a sink
NEC 2502

Optocoupler used as a source
NEC 2502

Note: Current through NEC-2505 should not exceed 150mA
Maximum Voltage for NEC-2502 is 30Vdc

© 1994 CircuitWerkes
All rights reserved

CircuitWerkes
3716 SW 3rd Place
Gainesville, FL 32607
(904) 331-5999 / fax 331-6999

Title: Typical Optocoupler Use Examples

Size	Document Number
A	REV

Date: September 17, 1994 | Sheet 1 of 1

Typical DTMF-16 output wiring.
Specific examples for interfacing the DTMF-16 to relays and TTL/CMOS inputs can be found on page 9.



CircuitWerkes

DTMF-16b Output Wiring

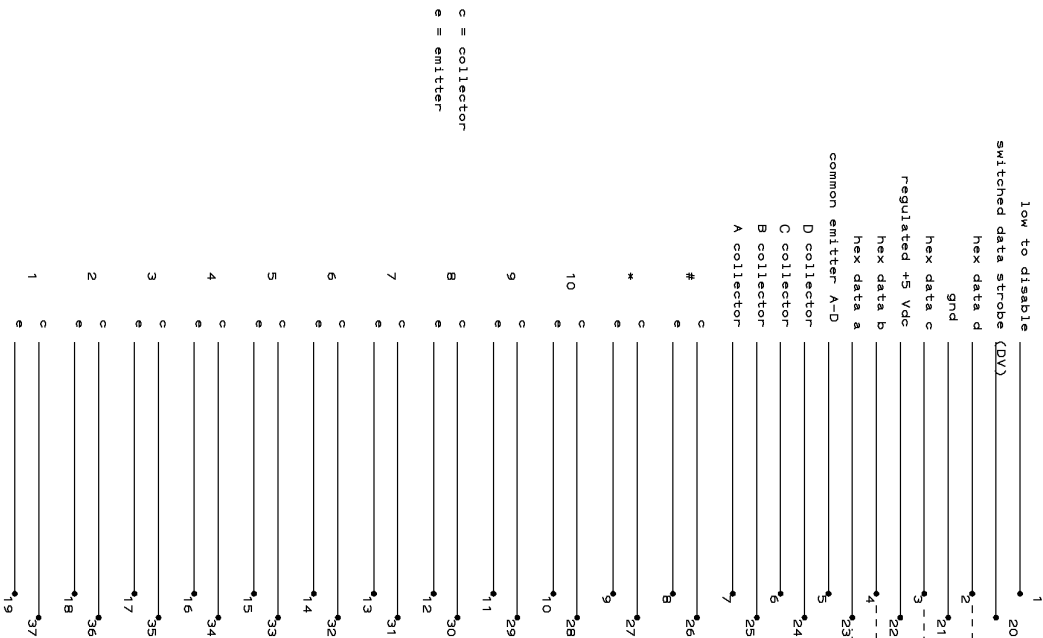

See Comblock or Silencer Instructions for more information on how to use pins 2,3,4, & 23. (See note A below)

Optional Comblock COMMON (not Ground) Pin Set Comblock Silencer Manual for usage in resetting the Comblock.

Optional Comblock UNLOCKED (Ground sink) output pins 15M when Comblock is Unlocked.

Optional Silencer Board AUDIO OUT BALANCED +

Optional Silencer Board Audio OUT Balanced - (not Ground)

DB37F pinouts on DTMF-16a Decoder Board

NOTE A :

Pin descriptions inside the dashed box are for units in which the related option boards have been installed.

The Comblock Option Board has a "piggy-back" or "daughterboard" that mounts on top of the DTMF-16 board.

The Silencer Board mounts beside the DTMF-16 board or above the AC-2 board on AD-16 models.

Please call us or your favorite CircuitWerkes dealer for details for more information. z



© 1995 CircuitWerkes
All Rights Reserved

CircuitWerkes 43 East Blvd, N. Macclenny, FL 32063 (904) 331-5999 or fax 331-6999	
Title	DTMF-16b Output Connector Wiring
Size Document Number	REV
Date: March 16, 1995	Sheet of

Sample hookup of slave relay on #1 output.

The relay will operate whenever the output is active.
This example is wired to operate with the #1 output.

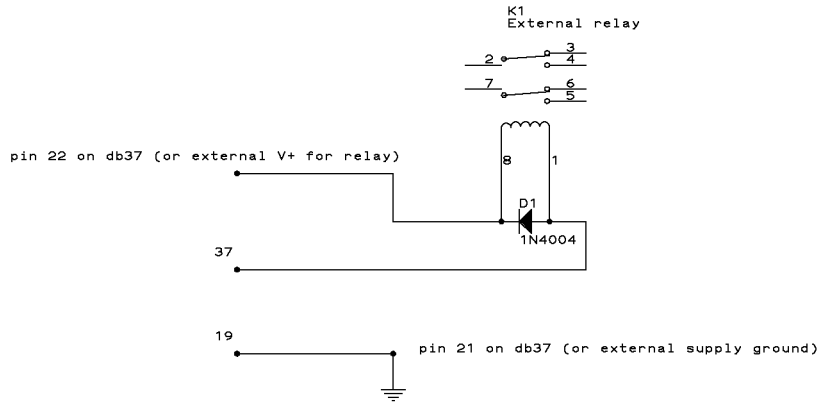

5

Regulated 5Vdc at up to 70mA is available at pin 22 for powering external devices such as relays. Pin 21 is ground. Larger external relays must be powered from an external supply.

NOTES :

Always use a reverse-biased de-glitching diode on the coil of the relay(s).

Maximum sink current for the (standard) Darlington output is 150mA.

CircuitWerkes		
Title	DTMF16 SAMPLE RELAY DRIVER	
Size	Document Number	REV
A		
Date:	October 29, 1993	Sheet of

Sample hookup of #1 output to pull logic input low.

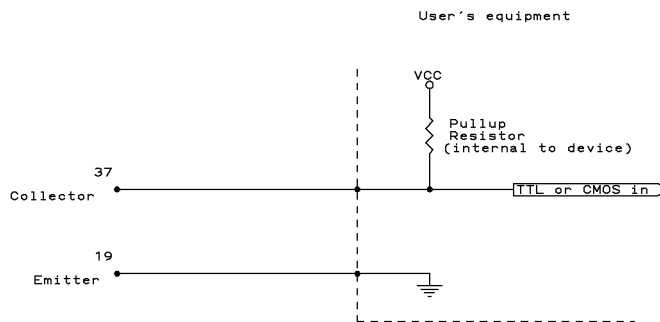

NOTES :

Never exceed 30 volts emitter to collector.

Some low current TTL or CMOS inputs may require use of non-Darlington open collector outputs. Non-Darlington output chips are available from the factory at no cost.

Size	Document Number	REV
A		
Date:	October 29, 1993	Sheet of

Sample hookup of latching slave relay on #1 output.

Relay, K1, will latch whenever the output is activated momentarily.
 This example is wired to operate with the #1 output, but any output can be used.

K1 will pull in when DTMF tone 1 is received and will latch itself on. K2's normally closed contacts are used to break the circuit when DTMF tone (#) is received, causing K1 to unlatch. Use the second set of contacts on K1 for your switching.

pin 22 on db37 (or external V+ for relay)

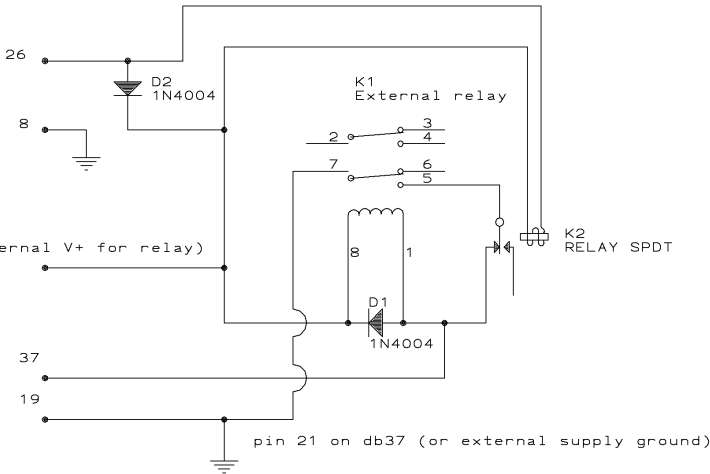

5 Volts at up to 75mA is available for relay power.
 +5Vdc is on pin 22 of the db37 connector. Gnd is pin 21.
 Optionally, you can power the relay(s) externally.

NOTES :

Always use a reverse-biased de-glitching diode on the coil of the relay(s).
 Maximum sink current for the (standard) Darlington output is 150mA.

CircuitWerkes 3716 SW 3rd Place Gainesville, FL 32607 (352) 335-6555/fax 380-0230 http://www.circuitwerkes.com		
Title		
DTMF16 SAMPLE LATCHING RELAY DRIVER		
Size	Document Number	REV
A		
Date:	May 11, 1998	Sheet of

REPAIR OR SERVICE INFORMATION

In the event of the need for service or repair, call CircuitWerkes at (352) 335-6555 for a Return Merchandise Authorization number (RMA). Then carefully package the unit along with a note of the problem and send it to the address below. Clearly indicate the RMA number on the outside of the box. We cannot accept returns without an RMA. Be sure to include your address (not a PO box), telephone number and best time to call.

CircuitWerkes

ATTN: CUSTOMER SERVICE DEPT.
 2805 NW 6th Street
 GAINESVILLE, FL 32609

<h3 style="margin: 0;">CircuitWerkes Limited Warranty</h3> <p style="margin: 0;">This product is warranted against defects for two years from date of purchase from CircuitWerkes and CircuitWerkes authorized distributors. Within this period, we will repair it without charge for parts and labor. Proof of purchase-date required. Warranty does not cover transportation costs, or a product subjected to misuse, accidental damage, alteration (except as authorized by CircuitWerkes), improper installation, or consequential damages. Except as provided herein, CircuitWerkes makes no warranties, express or implied, including warranties of merchantability and fitness for a particular purpose. Some states do not permit limitation or exclusion of implied warranties; therefore, the aforesaid limitation(s) or exclusion(s) may not apply to the purchaser. This warranty gives you specific legal rights and you may also have other rights which vary from state to state.</p>							
---	--	--	--	--	--	--	--