

DS-8c

Touchtone[®] Sequence Decoder

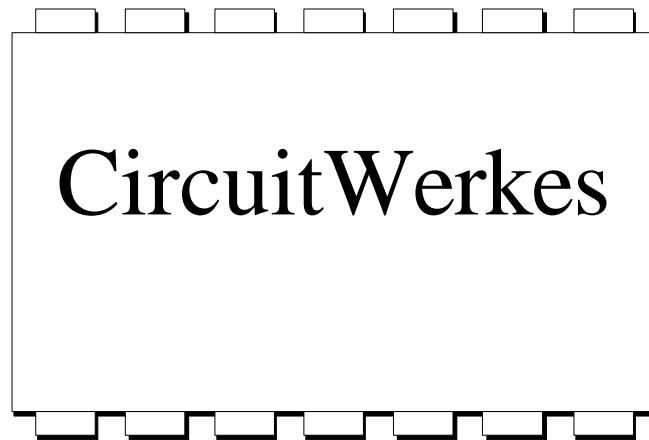

Technical Manual

CircuitWerkes

2805 NW 6th Street · Gainesville, FL 32609
(352) 335-6555 · Fax (352) 330-0230

© 1998-2003 CircuitWerkes All Rights Reserved. All information contained within is proprietary.
No part of this manual may be reproduced or copied without the express written consent of CircuitWerkes.

Touchtone[®] is a registered trademark of AT&T.

THANKS for buying the CircuitWerkes DS-8c. We are sure the DS-8c will give you years of faithful service. If you have comments, praise, questions or suggestions for improvement about this or any other CircuitWerkes product please call us at (352) 335-6555 or email us at info@circuitwerkes.com . We strive to constantly improve our products and that includes the technical manuals. Changes and updates are continuously made to our manuals. The latest copies of our technical manuals and product info on all our problem solving boxes can be found on our Internet web site at <http://www.circuitwerkes.com> or our mirror site at www.afn.org/~cwerkes/

Thank you for buying CircuitWerkes products. We appreciate your business!

PLEASE NOTE: Your unit may have been equipped with an audible tone annunciator (beeper) that activates whenever the status LED lights up. This feature is particularly handy when changing the relay codes as described on page 5 of this manual. In any case, if your DS-8c happens to beep when you power it up, don't be alarmed.

These beeps will normally occur only when you are changing the programming of your DS-8c; however, if you find the beeps annoying, just open up the box and remove the "buzz enable" jumper, J1, located beside U1, the largest chip on the board.

The CircuitWerkes DS-8c DTMF Sequence Decoder

Description

The CircuitWerkes DS-8c is a fourth generation, smart, DTMF sequence decoder that has eight independently programmed relay outputs. It comes factory set to provide momentary closures on seven relays and one in latching mode. Each relay having its own code(s) corresponding to popular network cueing/automation sequences. The setup information for each relay is stored in non-volatile memory, and is easily changed with a DTMF tone encoder or any Touch-Tone phone.

Installation

The DS-8c is very easy to install. The metal case can be wall mounted with two screws, set on a flat surface, or be rack-mounted with the optional rack-mount kit.

The connector layout for the DS-8c is shown below.

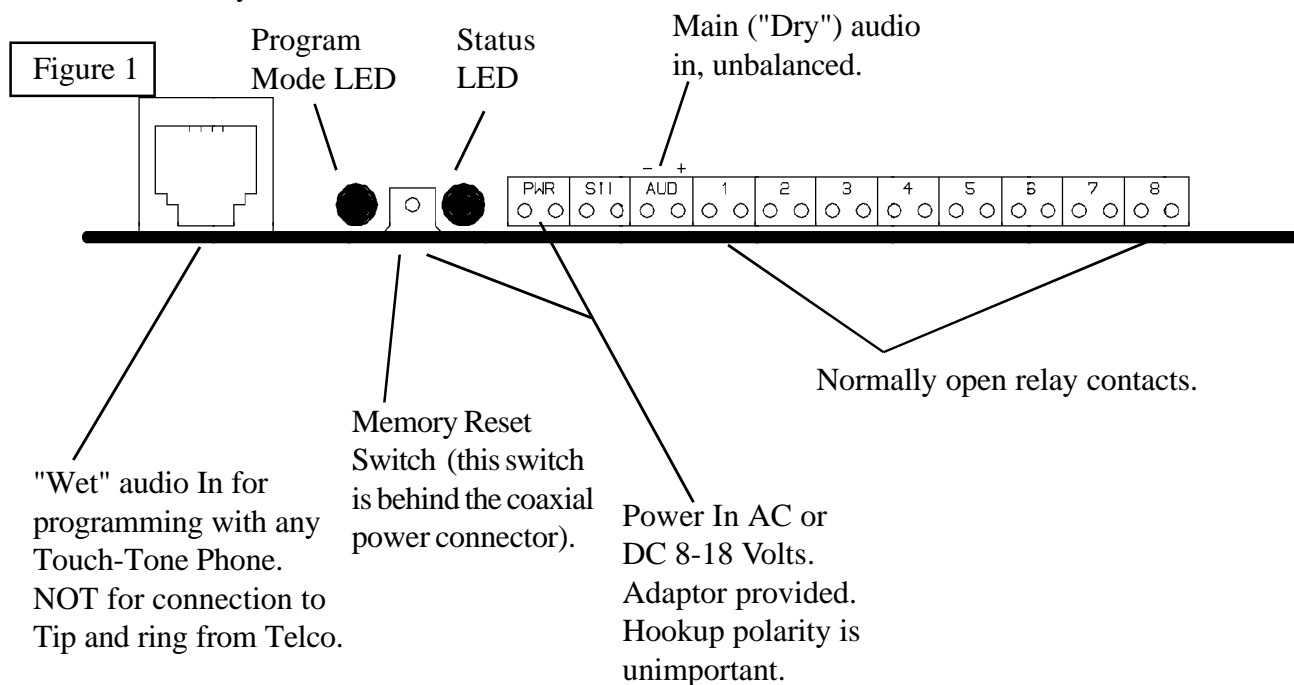

Power is applied to the first two screw terminals or to the coaxial "barrel" connector. The power inputs are in parallel, so power may be applied to either of them, but not both. Power may be either AC or DC. The normal audio input for the DS-8c is unbalanced on the third and fourth screw terminals. The DTMF input range is -15dBm to +6dBm. The RJ-11 jack is for programming the DS-8c with a generic Touch-Tone telephone. This connection provides power to operate the DTMF circuitry in the phone. Except for the RJ-11 being a wet (DC powered) jack for powering a telephone instrument, it is essentially in parallel with the main audio input; all DS-8c functions can be programmed or accessed from either audio connection. **DO NOT ATTACH** this device to a live telephone line. Your local Telco will be unhappy and you will probably blow up the onboard power circuitry, ac signal limiting, and who knows what else. Plugging the unit into a Telco line voids the two year limited warranty. The terminals marked Sil Out are for the Silencer option that removes DTMF tones from your audio path. If your DS-8c has a Silencer, its instructions are at the end of this manual.

The power requirement from the provided 12v supply (with no relays energized) is approximately 10mA; each energized relay adds about 10mA to the load. With all relays latched the unit will draw less than 100mA. The relay closures are rated at 10 watts each. If you need to switch line voltages we heartily recommend slaving big fat relays made for that purpose, in a protected enclosure. Safety first.

The DS-8c is newly equipped with an anti-falsing filter for use in noisy environments and when there is only a single DTMF tone being decoded. To activate the anti-falsing filter, you will have to remove the top of the decoder and place a jumper on J2. Tone detection will then be delayed for about a half second eliminating the possibility of noise causing a false output. Note that the anti-falsing filter should not be used when decoding sequences because the sequences are typically much too fast to be decoded with the filter on.

Operation

Once the installation is complete and you've energized power, the status led will blink with the number of the firmware revision letting you know the unit is ready to operate. The front panel has an LED for power and another LED for DTMF detection. The power LED should be on whenever the DS-8c is energized. The DTMF LED should come on whenever a DTMF tone is detected. The stock (default) codes and modes for each relay are shown in figure 2 below.

Figure 2

Relay #	Mode	Digits	ON code	Off Code
1	M	4	048*	N/A
2	M	4	048#	N/A
3	M	4	635*	N/A
4	M	4	635#	N/A
5	M	1	1	N/A
6	M	1	3	N/A
7	M	1	5	N/A
8	L	3	*12	#12

MODES:

The operation of each relay is described by the relay's mode. Although the default codes MOSTLY specify momentary relay action, any relay can be set up for any one of the following modes.

- M = Momentary. When the DS-8c receives the ON code the relay contacts close for approximately 200milliseconds. A single code operates this mode.
- L = Latching. When the DS-8c receives the ON code the relay contacts close and stay closed until the OFF code is received.
- XL = (Interlocked or Exclusive Latching)- All relays set up as XL type are just like normal latching (as described above) except that they are exclusive to each other. If a type XL relay is ON and another type XL relay is subsequently turned ON, the previously energized XL-type is automatically turned off. Regardless of how many of the relays are set up as type XL, only one type XL will be on at one time. The OFF code for the energized relay still works too.
- D = Disabled. This relay type does not respond to any incoming codes.

DIGITS

Each relay can be independently set-up for 1, 2, 3, or 4 digit code length, regardless of the relay's mode. All sixteen standard DTMF digits are valid digits.

Programming your DS-8c:

Programming is fairly straight forward. Relays are set up one at a time. Programming can be done with a DTMF encoder attached to the unit's Audio Input or with just about any telephone instrument that has a TouchTone® pad, plugged in to the DS-8c's RJ-11 jack (unfortunately most telephones are not capable of producing A,B,C, and D tones. See below for instructions on doing this with a standard phone or keypad). Programming a relay is as easy as dialing a telephone number; the DS-8c even acknowledges the steps along the way. You first enter the programming mode with a four digit password, then enter the relay number, then the number that corresponds to the relay's mode, the code length, the ON code, and the OFF code if the relay is a Latching or eXclusive Latching type.

The Default Programming Password is 9999.

The Mode numbers are : 1 = M (Momentary) 3 = XL (eXclusive Latching)
 2 = L (Latching) 0 = Disabled

If you make a mistake during the programming of a relay, just stop what you're doing and wait a few seconds for the device to time-out. It will automatically drop out of the programming mode (without saving incomplete changes) if no input is received for eight seconds. When each step of the process occurs, the STATUS LED blinks once. If an error occurs, like selecting relay 9 or type 4 (neither of which exists, the status LED will blink ten times then the DS-8c will leave program mode and wait for two seconds of silence (no DTMF tones) before accepting further input. The DS-8c does allow programming of DTMF tones A-D. If you push and hold S2 while entering tones 1-4, the DS-8c will record them as tones A-D.

EXAMPLES:

To program relay 1 as momentary output with a 4 digit code to be 635*

ENTER 9999	1	1	4	635*
programming password	relay#	mode	digits	code

Relay 8: Momentary, 3 digits, Code = 111

ENTER 9999 8 1 3 111

Relay 4: Latching, 4 digits, ON=4321, OFF=0000

ENTER 9999 4 2 4 4321 0000

Relay 2: XL, 4 digits, ON=222*, OFF=222#

ENTER 9999 2 3 4 222* 222#

IMPORTANT: THINGS TO CONSIDER WHEN CHOOSING NEW CODES

If you mix different-length codes on a DS-8c, you may countermand a longer tone with a shorter one. DS-8s with code revision 1.05 or higher end their decoding sequence when a valid code is detected, or when an erroneous tone is detected in a string. For example, if a relay is programmed with a 2 and another is programmed with code 23, the first 2 will be decoded but the second relay will never operate. However, you can now cascade as many valid tone sequences together as you want. For instance, if your second relay is programmed as 32 instead of 23, you can send sequence 322 or 232 which will cause both relays to operate in quick succession. If you want two relays to operate simultaneously, they can be programmed with identical on codes. The new firmware allows the DS-8c to be ready to decode new sequences of tones much more quickly than in earlier firmware revisions when it was possible to activate more than one relay with a single sequence of tones. In the old revisions, a two second timer exclusively controlled the DS-8 decoding. If a shorter code was the same as the beginning digits of a longer code, both functions used to occur. For example, if relay 1 had a single digit code of '3' and relay 2 had a three digit code of '325', both codes used to be received and both actions were taken if the 325 code is entered. If you would prefer your DS-8c to operate in this way, we will swap CPU chips with you during the first year of operation at no charge. Thereafter, we will happily sell you a new (old) CPU at a nominal charge.

CHANGING THE PROGRAMMING PASSWORD

If you wish to change the programming password, you first enter the default (or current) programming password, then enter an asterisk, then enter your new password twice. The programming password must be four digits.

Example: To change the programming password from the default password to 8888:

ENTER 9999 *8888 8888

Remember (better yet, write down) your password if you change it.

RESETTING TO FACTORY DEFAULT

If you loose your programming code or need to return the DS-8 to factory default, hold the reset button and power your DS-8c off and on while continuing to hold the reset. All programming and operating codes will return to original defaults. Note: this is changed from the earlier method of holding reset and entering a 1.

REPAIR OR SERVICE INFORMATION

In the event of the need for service or repair, call CircuitWerkes at (352) 335-6555 for a Return Merchandise Authorization number (RMA). Then carefully package the unit along with a note of the problem and send it to the address below. Clearly indicate the RMA number on the outside of the box. We cannot accept returns without an RMA. Be sure to include your address (not a PO box), telephone number and best time to call.

CircuitWerkes
 ATTN: CUSTOMER SERVICE DEPT.
 2805 NW 6th Street
 GAINESVILLE, FL 32609

CircuitWerkes Limited Warranty

This product is warranted against defects for two years from date of purchase from CircuitWerkes and CircuitWerkes authorized distributors. Within this period, we will repair it without charge for parts and labor. Proof of purchase-date required. **Warranty does not cover transportation costs, or a product subjected to misuse, accidental damage, alteration (except as authorized by CircuitWerkes), improper installation, or consequential damages**

Except as provided herein, CircuitWerkes makes no warranties, express or implied, including warranties of merchantability and fitness for a particular purpose. Some states do not permit limitation or exclusion of implied warranties; therefore, the aforesaid limitation(s) or exclusion(s) may not apply to the purchaser. This warranty gives you specific legal rights and you may also have other rights which vary from state to state

