

CIRCUITWERKES
Makers of Innovative Electronics

Operation & Technical Manual

SiteSentry4 & SiteSentry4-LE Web Based Remote Site Monitor & Controller

Firmware Version 1.5 / Software v1.4
Revised 1/21/2014

Hardware Version 1.1
Manual Rev 1.2

Table of Contents

Contacting CircuitWerkes.....	5
Unpacking your SiteSentry4.....	5
Safety Information.....	5
Product Overview.....	6
Introduction.....	6
Standard SiteSentry4 Inputs and Outputs.....	6
SS4-LE Inputs and Outputs.....	8
Connecting your SiteSentry4 to other equipment.....	9
Metering Inputs.....	9
Relay Outputs:.....	9
External Status Inputs.....	9
Using the Internal Web Server.....	10
Connecting to the SiteSentry4 for the first time:.....	11
Using the SiteSentry4's Web server:.....	12
Logging In:.....	12
Monitoring and control using the Web server:.....	13
Calibrating Meters:.....	15
Setting Alarm Points:.....	17
Event Triggers:.....	18
Sequences:.....	19
Logging:.....	20
E-mail notifications Setup.....	22
Connectivity (Network settings):.....	23
Passwords and system utilities:.....	24
Saving Your Unit's Configuration Data to Your PC:.....	24
Optional Streaming.....	25
Receive Audio hardware:.....	26
Date & Time:.....	27
Event Scheduler:.....	28
Firmware upgrades.....	29
Specifications.....	30
SiteSentry4 Schematic. Note the SiteSentry4-LE is similar but lacks the balanced audio input/output.....	31
Warranty.....	32

NOTE: This technical manual & information presented within is subject to change.

Contacting CircuitWerkes

For help with setting up or operating the SiteSentry4, please contact us at the following:

Phone: 352-335-6555

E-mail: info@circuitwerkes.com

Website: www.circuitwerkes.com

Unpacking your SiteSentry4

Note: CircuitWerkes is not responsible for product damage during shipment. Inspect your shipment carefully for external signs of damage. CircuitWerkes suggests that you unpack your shipment as soon as possible after receipt to inspect it for signs of damage that might not be visible from the outside. If the shipment appears to be damaged, keep the original boxes and packing material for inspection by the carrier. All damage claims should be made directly to the carrier. Do not delay. Call the carrier as soon as damage is discovered.

You should have received the following items with each SiteSentry4 that you have purchased:

- [] (1) CircuitWerkes 15V Power Supply
- [] (1) Standard Network cable (yellow)
- [] (1) Printed copy of the manual

If you have not received all of the items shown with your shipment, please carefully check inside the box or boxes because items occasionally get lost in the packing materials and can be hard to find. If your items are not found, please call CircuitWerkes at 352-335-6555 or e-mail us at support@circuitwerkes.com.

In case your product is in need of service our shipping information is as follows:

CircuitWerkes, Inc.

Attn: RMA #

2805 NW 6th Street

Gainesville, Florida, 32609, USA

Please obtain an RMA from us and verify the address before returning any products



Safety Information

WARNING!

The SiteSentry4's relays are not intended to switch hazardous voltages. The exposed terminals make connecting such voltages to the SiteSentry4 extremely dangerous and it should never be attempted. The terminal strips are not designed to shield humans from potentially dangerous Voltages. Contact with high Voltages can cause serious injury or death. The maximum recommended Voltage for the SiteSentry4 is 30V. Switching of high voltages should only be done externally and in a manner that isolates the voltages from accidental contact with people.

Surge Protection

Although the SiteSentry4 has built-in resistance to voltage changes, we recommend that you use a power surge protector or line conditioner on the incoming AC line. Lightning strikes and other high surges in voltage levels will damage your SiteSentry4 and connected equipment if it is not properly protected.

UPS Standby Power System

We recommend that you connect your SiteSentry4 to a battery backup system. While all operating and user parameters are stored in non-volatile RAM, brownout conditions and lightning induced spikes can disable or damage equipment. A UPS helps minimize the risk to the SiteSentry4 and has the added benefit that it will then be able to notify you of the power outage by SMS or e-mail, depending on the configuration of your system.

Product Overview

Introduction

The CircuitWerkes SiteSentry4 is a Web enabled Remote site controller and monitoring tool. An internal Web server lets you visually monitor your site from any Web browser, anywhere in the world. When an alarmable condition is detected, the SiteSentry4 can perform user-programmed, automated, sequences of actions and can also respond to user control via the network or via external contact closure inputs. Three levels of user control are available ranging from reader up to administrator.

The SiteSentry4 is available in two versions. The standard SS4 is equipped with active, balanced, audio inputs and a calibration control for each audio input. There is also an audio streaming input control for each channel, available when the optional streaming module is used.. Additionally, when used with the streaming module, the standard SS4 supports a stereo balanced audio output module for use with receive audio streams.

The SS4-LE version offers the same DC metering and relay controls but the audio metering input is unbuffered and unbalanced. The streaming option is also not supported on the LE version. Both versions of the SS4 audio metering can detect silence or overload.

In addition to the four DC metering inputs, an onboard temperature sensor allows you to monitor the local temperature.

Up to two SiteSentry4s can be optionally rack mounted in a single sized rack shelf. Administrators can perform all setup through the Web server.

Key Features

- *Internal Web Server lets you see your status from anywhere in the world*
- *Web server meters respond quickly*
- *Four balanced DC metering inputs*
- *Stereo audio monitor input*
- *Onboard temperature sensor*
- *6 User-programmed relays (2 DPDT) close automatically or via Web control*
- *81 User-definable alarm conditions can trigger up to 7actions per alarm*
- *External trigger inputs can activate user-defined actions*
- *Relays can be momentary or latching.*
- *DHCP or Static IP capable*
- *Onboard e-mailing & texting of alarms*
- *Onboard logging w/periodic e-mailing*
- *Field upgradeable firmware keeps you up to date..*
- *Optional audio streaming upgrade available (can send or receive).*

Standard SiteSentry4 Inputs and Outputs

As seen in Figure 1 below, the SiteSentry4 has a number of connectors on the back panel to interface with your equipment. The following table is a list giving the name of each connector, followed by a brief description of its function.

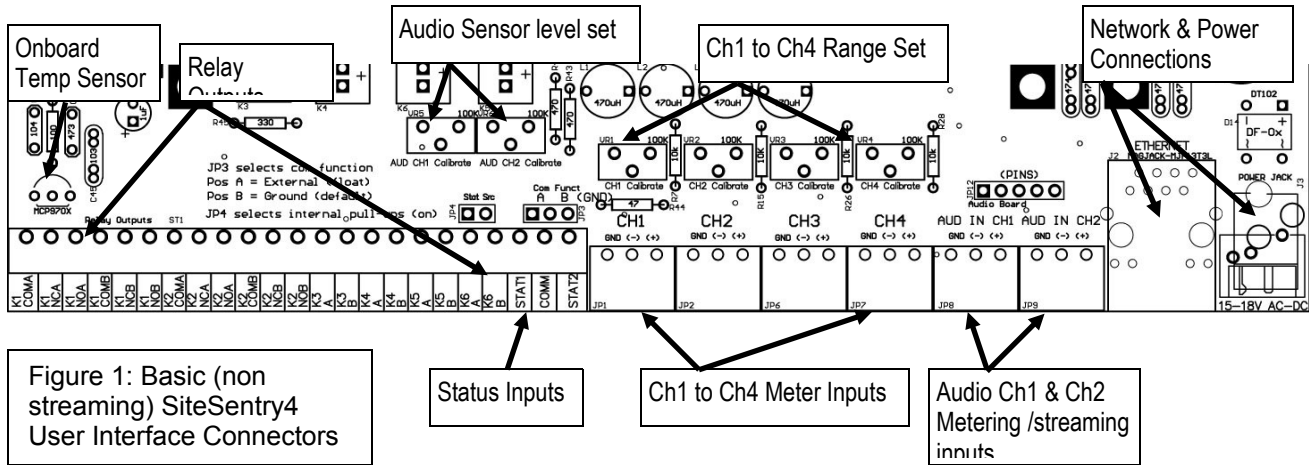

Standard SiteSentry4 Back panel connections

Name	Type	Description
Relay Outputs	Screw Terminals	The SiteSentry4 has six relays. These relays are not associated with any particular metering channel. They are completely independent and any event on either channel can be used to operate any relay. Everything is completely user defined.
Ext 1 & 2	Screw Terms	External Status inputs. Can trigger actions/alarms.
Network	RJ-45	Connects your LAN or Internet to the internal Web server.
Status LEDs	G & Y LEDs	Blinking yel = proper operation. Solid green = Net connected.
Input 1	3-terminal	Site input to feed channel 1 analog input for site monitoring.
Input 2	3-terminal	Site input to feed channel 2 analog input for site monitoring.
Input 3	3-terminal	Site input to feed channel 3 analog input for site monitoring.
Input 4	3-terminal	Site input to feed channel 4 analog input for site monitoring.
Ch1 thru 4 Cal	Trimmer	Adjusts the input level to the # A/D converters (range set)
Stat Src	Jumper	Select internal or external voltage source for status inputs
Com Funct	Jumper 1x3	Select com=ground or com=floating for status inputs
Audio In	3-terminal	Unbal. Stereo audio input for remote (visual) audio monitoring.
CH1 & CH2 Cal	Audio Trimmer	Adjusts the input level to the audio A/D converters (range set)
Power In	2.1mm Barrel	Accepts 14-18 V AC or DC @ 200mA

Important Note: the DPDT relays are rated at 1Amp while the SPST relays are rated at 10va or 100mA (non inductive).

SiteSentry4 Front panel indicators:

Name	Type	Description
PWR	LED Indicator	Indicates that the main power supply is operating.
Link	LED Indicator	Lights up whenever the network is connected
Cust 1	LED Indicator	Lights when a user defined event triggers this LED
Cust 2	LED Indicator	Lights when a user defined event triggers this LED

SS4-LE Inputs and Outputs

As seen in Figure 2 below, the SiteSentry4 has a number of connectors on the back panel to interface with your equipment. The following table is a list giving the name of each connector, followed by a brief description of its function.

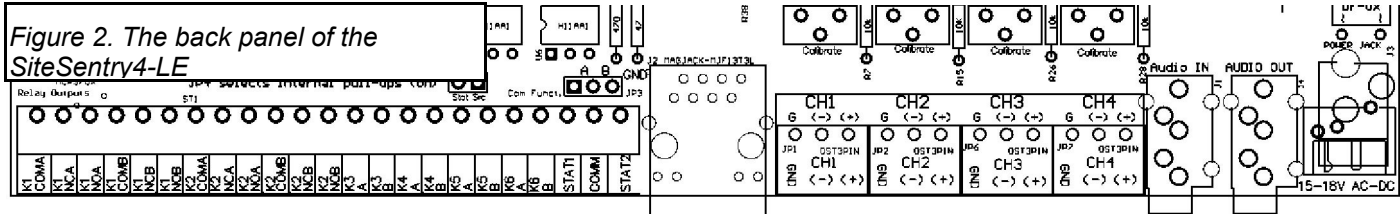

SS4-LE Back panel connections

Name	Type	Description
Relay Outputs	Screw Terminals	The SiteSentry4 has six relays. These relays are not associated with any particular metering channel. They are completely independent and any event on either channel can be used to operate any relay. Everything is completely user defined.
Ext 1 & 2	Screw Terms	External Status inputs. Can trigger actions/alarms.
Network	RJ-45	Connects your LAN or Internet to the internal Web server.
Status LEDs	G & Y LEDs	Blinking yel = proper operation. Solid green = Net connected.
Input 1	3-terminal	Site input to feed channel 1 analog input for site monitoring.
Input 2	3-terminal	Site input to feed channel 2 analog input for site monitoring.
Input 3	3-terminal	Site input to feed channel 3 analog input for site monitoring.
Input 4	3-terminal	Site input to feed channel 4 analog input for site monitoring.
Ch1 thru 4 Cal	Trimmer	Adjusts the input level to the # A/D converters (range set)
Stat Src	Jumper	Select internal or external voltage source for status inputs
Com Funct	Jumper 1x3	Select com=ground or com =floating for status inputs
Audio In	3.5mm Stereo	Unbal. Stereo audio input for remote (visual) audio monitoring.
Power In	2.1mm Barrel	Accepts 14-18 V AC or DC @ 200mA

SiteSentry4 Front panel indicators:

Name	Type	Description
PWR	LED Indicator	Indicates that the main power supply is operating.
Link	LED Indicator	Lights up whenever the network is connected
Cust 1	LED Indicator	Lights when a user defined event triggers this LED
Cust 2	LED Indicator	Lights when a user defined event triggers this LED

Important Note: the DPDT relays are rated at 1Amp while the SPST relays are rated at 10va or 100mA (non inductive).

Connecting your SiteSentry4 to other equipment

Metering Inputs

The SiteSentry4 has four, differential, DC site inputs that it monitors. The inputs are ground referenced. These are on depluggable (“Phoenix” style) connectors. Gain control potentiometers are associated with each DC input to let you calibrate your site level to the internal metering of the SiteSentry4. Normally, you will apply the highest expected metering sample to the input and then set the meters for 2/3 to 3/4 of full scale using a scale factor of 1.0 (default). This sets the nominal range of the A/D converter. You can then scale the sample in firmware to read whatever you want. In addition to the DC metering inputs, the standard SiteSentry4 has balanced audio inputs & the SiteSentry4 LE has a 3.5mm, unbalanced, stereo audio input for metering of local audio. **The typical metering configuration is to hook positive sample voltages between (+) and Ground.**

Relay Outputs:

The SiteSentry4 is equipped with 6 relays to provide you with control over your external equipment or to switch audio.

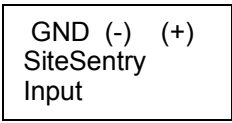

Relays K1 and k2 are DPDT relays which are ideal for use as a simple stereo audio switcher. All relays can also be operated in momentary mode, so they can be used as standard control outputs, as well. All six contacts of each DPDT relay are brought out on the back panel barrier strip, so any and all of their contacts may be utilized. The DPDT relays are labeled Common (ComA or ComB), Normally Open (NOA or NOB) and Normally Closed (NCA or NCB). A and B refer to which set of contacts are being used. The COM contact is connected to NC when the relay is off and the COM contact is connected to NO when the relay is energized. Electrically, it is possible to make contact closures between all of the A or all of the B but A and B sides are isolated from each other. Each of the remaining four relays are normally open SPST (form A) contacts that can be used for general control purposes. The SPST relays are rated at 10va, non-inductive. Higher loads may damage them. The DPDT relays are rated for 1A max., non-inductive. None of the relays have voltages sourced to the contacts internally. All closures are dry (no voltage is supplied on any of the contacts).

External Status Inputs

The SiteSentry4's status inputs can be used to determine the status (on/off) of your equipment. The status input connectors are located immediately to the left of the network connector and are labeled Stat1 and Stat2 and common. The optocouplers are bi-directional meaning that current can flow in either direction. This means that these inputs can be triggered by supplying a voltage to them or by supplying an internal voltage and pulling them to ground. The operation of these inputs is determined by the settings of JP3 and JP4. By default, the status inputs are pulled up internally. The com terminal is jumpered to ground. These inputs accept contact closures to ground as inputs, or you can supply AC or DC voltage to them by changing jumper configurations. Max input voltage is 15V and jumper JP4 must be “off” before an external voltage is supplied. Status inputs can be used to trigger actions when closed or opened. When applying your own voltage, the polarity is not important. The optocouplers will conduct in either direction. When using the Status inputs with the internal power supply, you will need to connect your device's ground to the SiteSentry4's actual ground (JP3 in B).

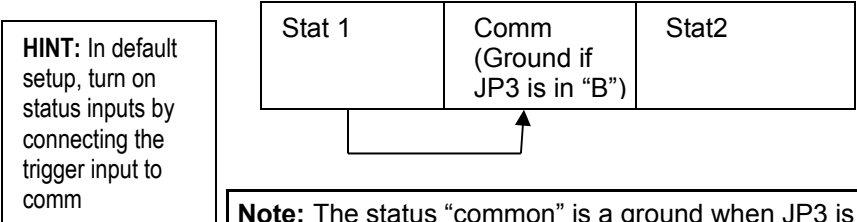
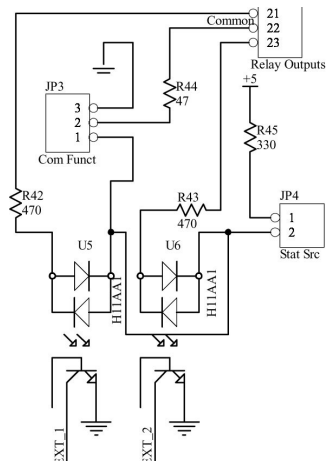

HINT: In default setup, turn on status inputs by connecting the trigger input to comm

Note: The status “common” is a ground when JP3 is set to the “B” position (default). If JP3 is set to “A”, then comm is floating and can be used to source a voltage to the optoisolators. If sourcing a voltage, JP4 (the internal pull-up) should also be removed.

Using the Internal Web Server

Networking basics:

Before reading any further, we would like to mention that the following section is not intended to be a comprehensive guide to networks, nor does it necessarily describe your network. Indeed, we have found that networks vary quite a lot and yours will probably be different than is described here. We assume that you, or a network administrator, is familiar with your network and knows how to set it up to accommodate Web servers that exist within your network. The brief discussion provided below is only intended to be used as a very non-specific description of how a network might function.

In Internet land, devices on your network get unique IP addresses because each piece of hardware has a serial number embedded into it. Every device with a serial number, called a MAC address, has to get an IP address assigned to it in order to function using the networking protocol called TCP/IP, which is what is used for the Internet. The router in your network uses those IP addresses that it assigns to keep track of what data requests have been made and how to route responses to the devices that need data. In a way, the IP address is sort of like a nickname that computers use to talk to each other. A computer will only respond if it has been called by name. So, the IP addresses are what one computer uses to address or talk to another computer. The router also uses those IP addresses to manage the flow of communications between each computer so that they are not all talking at once like an old fashioned party-line.

IP addresses are usually doled out within a fixed range, so it's also easier for humans to remember a device's location via its IP address than to try to remember every item's MAC number. For instance an internal network might use the IP range of 192.168.1.### where ### can be 001 through 254. Once the network administrator has set up the address range, he or she only has to keep track of what's assigned to the last three digits of the address range.

Generally, simple networks are divided into two sets of addresses. There are the addresses that exist inside the network (called the private or LAN side) and then there are addresses that exist on the Internet (public or WAN) side of the network. We've already described the private side above, but getting stuff on the private side to talk to the public side can be tricky.

When you have one device that is connecting your internal network to the Internet, like a cable modem or DSL modem, it also has a unique serial number, so it gets assigned an IP address from your ISP. But the ISP only sees the modem, not other equipment on the inside of your network, so they cannot assign multiple IP addresses (actually they can, but that's another story). Although you probably only have one IP address, you will have a whole range of port numbers that you can use for each IP address that exists on the private side of your network. Usually, different types of communications use standardized ports to talk to devices. For instance http (Web browsing) is mostly done on port 80. FTP is usually port 21. E-mail might use port 25. Often, we want to set our network connection up to pass port 80 to some device on our network, like the SiteSentry4, that serves up web pages. We do that by telling the router/firewall to pass port 80 requests to the IP address that we know we have previously assigned to the SiteSentry4. To do that, we have to tell our firewall that it's okay to send port 80 requests to the SiteSentry4, otherwise it'll just block those requests if they come from the public side of the firewall. As described earlier, each device on the private side needs a static IP address that is set by the network administrator. So, each item on the inside of a network that will be communicating with the outside world has to have an IP address within the local network **AND** it must also have the appropriate port opened on the firewall. On the Internet side of the firewall, there is usually only the main IP address and the port number.

When you put it all together it might look like this:

Public IP address 67.234.98.135, port 630 could be mapped to internal IP address 192.168.1.200, port 80. So a browser request made to 67.234.98.135:630 would serve up a web page because you would really be talking to 192.168.1.200:80. Once you have that properly configured, your SiteSentry4 can serve up Web pages from inside of your network to the Internet.

Connecting to the SiteSentry4 for the first time:

Most networks use a router as their central hardware. When a device is plugged into a router, the device normally obtains an IP address from the router using a process called DHCP. By default, the SiteSentry4 obtains a DHCP address from your network's DHCP server. In order to connect to the SiteSentry4, you can use one of two methods: First, the device has a default netbios name of "sitesentry4". You can type sitesentry4 (no www) into your browser's address bar and it should take you to the login screen. On some browsers, you must enter the entire <http://sitesentry4/> including the starting "http" and the backslash after the 4. Some browsers will work either way. Note that netbios names are not supported in some operating systems such as Android. The second method requires you to know what its network IP address is. An IP address inside a network will usually look like XXX.XXX.X.XXX, for example 192.168.1.100. Your router knows this information and you can usually find out what the address is by logging into the setup page of your router. Most routers have a page that shows the attached devices. This can be shown as part of the router's DHCP page, or it may be shown in a separate LAN discovery page. Once you know the IP address of your device, you will be able to connect to it by entering the address into your browser's address bar. You can use the CircuitWerkes *Netscanner* utility, found on our Website or on the CD that came with your SiteSentry4 to locate the device on your network. Netscanner will identify the SiteSentry4 by name and will show you the IP addresses of all objects on your network that respond to pings.

If you do not use a router in your network or if you want to configure your SiteSentry4 via a direct crossover connection, **the default IP address for this device is 192.168.1.200**. Note that some versions had a default IP of 192.168.0.200. If making a direct connection, you must set your computer's network settings to match the SiteSentry4's settings. Your PC's TCP/IP properties should be set to 192.168.1.xxx with a netmask of 255.255.255.0. Once you have connected to the SiteSentry4, you can set its IP address to whatever you wish from the configuration page.

The Web server uses port 80, but this can be changed after login. Often, sites have multiple devices that want to use port 80, including some routers. You have two choices: first, you can change ports on the SiteSentry4's Webserver. Second, your router can simply redirect a different outside (WAN) port to the individual Web servers' inside IP addresses. For instance, the SiteSentry4 and another device each have Web servers using port 80. The SiteSentry4 has an internal IP address of 192.168.1.200 and suppose that the other device has an IP of 192.168.1.250. If you are on the inside (LAN) of the network everything looks great. You can browse to either device and everything works. To access the site from the outside, you must open a "pinhole" that allow data to pass from browsers to your SiteSentry4. You can encounter a problem if you try to route WAN port 80 to LAN port 80 for both Web servers. Only one will be assigned. You will not gain access to the second one. Instead, redirect LAN port 80 for each device to a different outside port, such as 800 and 801. In practice, you would access your site by entering its IP address followed by a colon and the port number (xxx.xxx.xxx.xxx:800), or by its URL name followed by the port (www.mysite.com:800).

Differentiating multiple devices on a common network:

The SiteSentry4 MAC address is not changeable, IP address and Netbios name of the device. These can be important when multiple CircuitWerkes Webserver based products are used at a common location. In that case, you will want to assign a unique MAC address to each box so that your network can distinguish between them. Likewise, you should change the Netbios name so that each device can be found by a unique name.

Using the SiteSentry4's Web server:

Your SiteSentry4 contains an onboard Web server which is the heart of its monitoring capability. This Web server has proved to be very stable & supports multiple browsers. Although the interface looks simple, the real power of the Web server lies “under the hood”, in its speed. Readings are continually updated, at a user defined speed, which is much faster than many competing products. Your actual speed depends upon the network and upon your PC’s horsepower. Your PC reads the raw data from the SiteSentry4 and “draws” the meter movements. Your computer’s ability to draw quickly has a direct effect upon how frequently the meters move. The default update speed is 500ms which updates the meter position 2x each second. Speeds of 50ms can be achieved on fast networks, however, if you request data too fast, your network or your PC may not be able to handle it and you can get a periodic message saying that the SiteSentry4 is not responding. If that happens frequently, slow the updating down by using a bigger number in the “Update Interval” box.

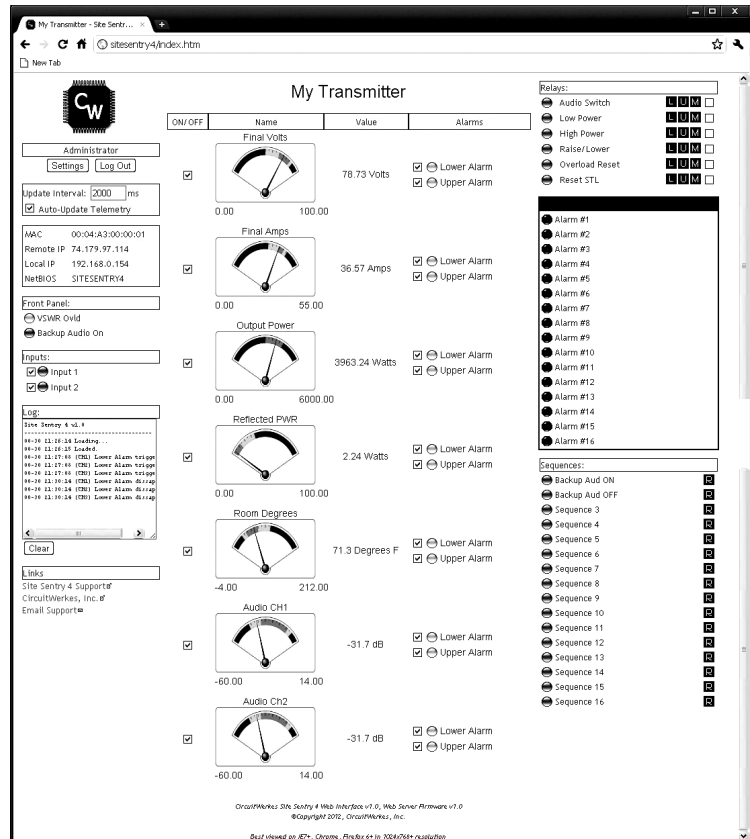

Logging In:



By browsing to whatever IP address your SiteSentry4 has, you will be presented with a login screen. **The default administrator’s login is 12345678**, unless you have previously set this differently from the configuration menu. There are three access levels to the SiteSentry4, reader, controller and administrator. Only administrators can configure the SiteSentry4. Controllers can operate relays while reader level has no control. The default administrator’s password is simply 12345678. Passwords are a maximum of 8 characters.

If you are using Internet Explorer and you incorrectly enter the password one time, you may have to close your browser and reload it because IE cache’s the passwords and will try to use them even if they don’t work and you have tried to enter a different password. To avoid that problem change your IE settings for temporary files so that Explorer checks for new versions of stored pages on every visit. Other browsers such as Firefox, Opera and Chrome do not, generally, have this problem, however, we still recommend IE be used for changing configuration of the SiteSentry4. Any browser can be used for monitoring.

Once you have entered the correct password, it will take a few seconds to load the SiteSentry4’s page. Once done, you will have access to the metering and controls of the SiteSentry4. If you are an administrator, you will also be able to manage the SiteSentry4’s settings. If the page does not properly load the first time, use the F5 key to refresh the page.

Monitoring and control using the Web server:

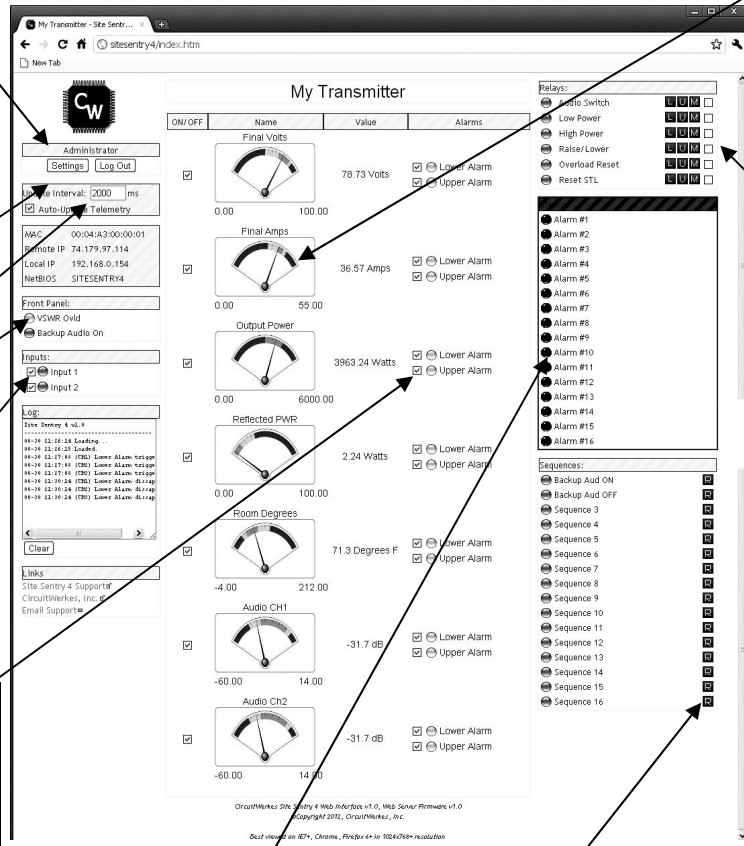

Displays Current Access Level

Settings button opens the configuration menu in a new window.

Update interval defines how often your meters move. Event Indicators: Cust 1 & 2 light when user-defined events occur. Ext 1 & 2 show when either of the two external status inputs are closed.

Upper and lower trigger selector boxes. Unchecking these boxes will keep the unselected state from triggering an action.

Alarm trigger indicators show which triggers are active.

Sequence Status & Control: This box shows you all of the available sequences. The indicators at left of the labels change color to show active sequences. Controllers or administrators can manually run any sequence by pushing the "R" button. This is a very powerful control since it can perform multiple programmed steps.

Metering. Green background indicates normal operation. Red indicates an out-of-tolerance condition. Grey means that channel is not being monitored.

Relay controls: U is unlatch, L = Latch and the "M" button is momentary for duration of mouse-down (2sec max). Two "check boxes" have been added next to each relay function. One disables momentary and the other disables latching modes. When checked, this box disables changes to that relay mode, be it automated or by Web control. The "checked" relay functions will be greyed out. For example, if a relay is latched and an automated script would have unlatched it, the relay will remain on, if the latch mode for that relay is "checked".. Uncheck the box for normal function. The indicators at the left of the labels show the relay's state. The indicators are polled at the hardware level to show you when a relay has closed, however, if the update interval is slower than the relay on time, the state may not be displayed. In other words, if the update interval is set for 2 seconds and you operate the relay for 1/2 second in the middle of the two second interval, you might not see the response from the relay that it had closed.

The SiteSentry4's Web server display gives you the ability to monitor four DC metering channels, a stereo audio channel, a temperature sensor and to control six relays. Four of the relays are SPST and two are DPDT, suitable for either controlling external equipment or for switching audio. Relays can be latched or momentary.

The SiteSentry4 also has two status inputs. Their status is shown in the upper left side of the screen as "Ext 1" and "Ext 2". When their inputs are connected to ground, the associated indicator turns from gray to green. External status inputs can also be used as events to initiate alarm actions.

Administrators can disable monitoring of meters or status by unchecking the boxes next to the indicators.

SiteSentry4 Configuration:

Administrators and controllers can operate relays and view the meters. Readers can login to see the meters, but cannot control anything. Administrators can read meters, operate relays and perform configuration setup tasks, including editing labels by just clicking on them from the main page. Calibrating (scaling) readings, setting the meter scales and changing labels can be done without ever opening the configuration page.

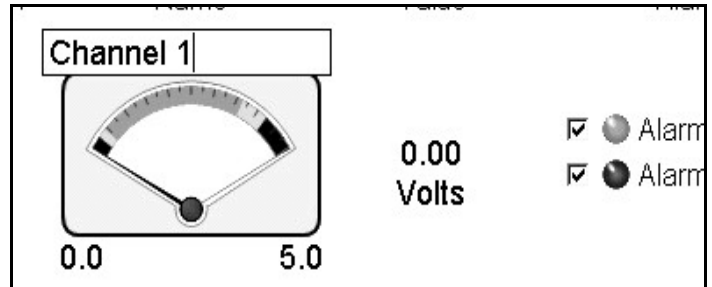

Above: Quick-changing a Label (Admin Only)
Below: The main settings Form

In addition to quick changing the labels and calibrations, administrators can click on the “settings” button to open up the main configuration form in a new window.

The configuration form has 7 tabs. Each tab lets you configure a different aspect of the Site Sentry. Tasks available include setting a static IP address, setup passwords for the various access levels, changing label names, defining under-voltage or overload levels for each channel and specifying the delay before an event is registered as an alarm and starts an action sequence.

Changes are highlighted in green or red until saved. Changes highlighted in red are illegal operations (for example, setting an upper alarm limit lower than the lower alarm limit for a channel) and won't be saved.

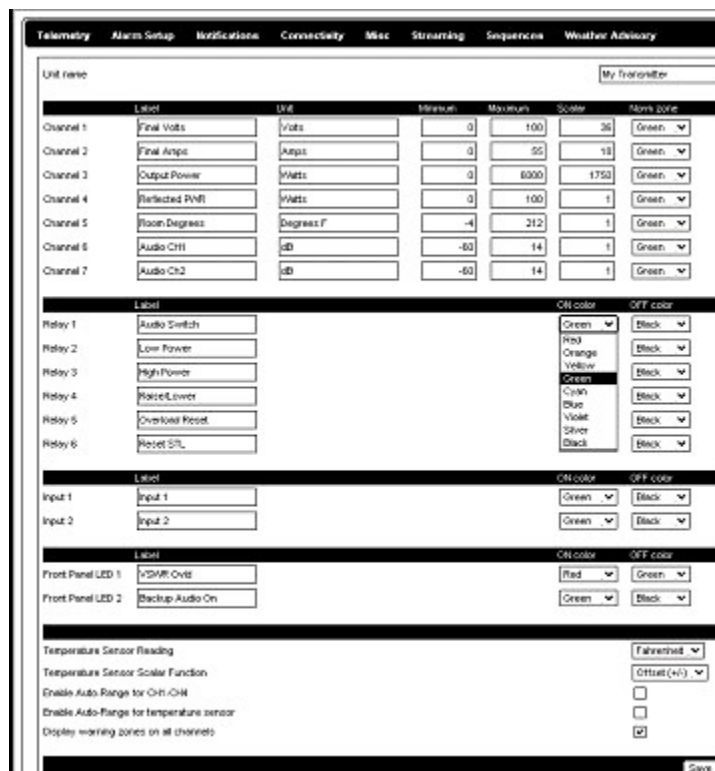

The action sequences are user-defined functions that the SiteSentry4 will perform whenever an event is triggered. These events are often called alarms, but they can also be simple responses to any particular input as defined by you.

The “alarms” are defined by two sets of parameters:

1. The triggering event
2. The step, or steps that you want to take when an event occurs.

Calibrating Meters:

Only administrators can calibrate the meters. This is best done when the output of your equipment is at its nominal operating voltage. Each input (except for onboard temperature) has a calibration control that is physically associated with the channel. The meter scale can be manually set or can be self-adjusting based upon where the pointer is and what value you assign to that metering input. Meters can be calibrated in just a few simple steps:

1. Log into the Web server for the SiteSentry4.
2. Apply a voltage sample to be monitored to the SiteSentry4's input.
3. Use that channel's calibration control to set the pointer to approximately the right spot on the dial. For most users this will be around $\frac{3}{4}$ of the way to the right side of the metering display
4. Set the meter's maximum scale so that the value you will be using will be within the meter's operational display range. For example, if you are currently reading 3.5, but will want the meter to read 5,000, click on the upper scale value and enter a number bigger than 5000, like 7000. The meter will rescale itself and your present value of 3.5 will be pegged to the bottom of the meter.
5. Click on the value currently displayed. This will allow you to directly enter the value that you want to record. When through, hit the enter key to set the value. The meter pointer will now move to the proper location on the meter face. The digital readout will also now reflect the correct reading. You can also adjust the scaling factor on the telemetry configuration page.
6. Note that if you set the meter pointer to extend beyond the upper scale, the meter will read overload, even if there is still range in the A/D. If autorange was previously selected in the telemetry setup, the full scale value will self-adjust.

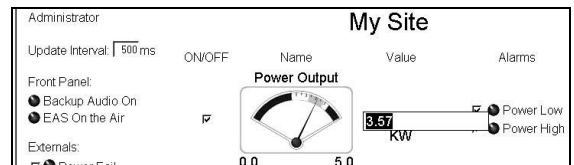

Note that calibrations are linear only. If your equipment outputs power or log scaled voltages, the readings will only be accurate at the calibrated voltage.

I/O Functions Quick Reference:

Meters 1-4 are the DC inputs. (differential, ground referenced).

Meter 5 is the onboard temperature sensor

Meters 6 and 7 are Channel 1 and Channel 2 (L & R) audio inputs. (Unbalanced, no gain controls on SS4-LE, Balanced, with gain set on the standard SS4).

Status inputs 1 & 2 are factory configured to turn on when the individual inputs are tied to "comm" or ground. These can be reconfigured for other types of drive circuits.

Relays 1 and 2 are DPDT.

Relays 3 through 6 are SPST.

Hysteresis: Hysteresis is a way of preventing marginal values from causing repeating alarms. When hysteresis is turned used, a value that causes an alarm is not considered normal until it has crossed out of both the alarm limit and the hysteresis limit. For example, an audio channel might have a lower alarm limit of -20dBm and a lower hysteresis setting of -10dBm. If the audio crosses below -20, an alarm occurs. In a typical system without hysteresis, if the audio level rises to -18, then falls to below -20 again, another alarm is generated. A system using hysteresis works slightly differently. As in the first case above, when the level falls below -20, an alarm occurs. However, no new alarms can occur unless the audio rises above both the -20 threshold and the -10 hysteresis limit, so signals that are hovering just around the alarm limit won't keep bothering you. The use of hysteresis combined with delay timers will keep most alarms from repeatedly bothering you.

The Telemetry Setup Tab of the SiteSentry

The screenshot shows the 'Telemetry' tab with several sections: Channel 1-7, Relay 1-6, Input 1-2, and Front Panel LEDs. Callouts point to specific fields:

- User Defined Channel Names:** Points to the 'Label' column in the Channel 1-7 table.
- User-set Unit Labels:** Points to the 'Unit' column in the Channel 1-7 table.
- Relay Labels:** Points to the 'Label' column in the Relay 1-6 table.
- Status input & front panel LED labels:** Points to the 'Label' column in the Input 1-2 and Front Panel LEDs tables.
- Color Selections:** Points to the 'ON color' and 'OFF color' dropdowns for Relays and LEDs.
- Meter min & max scale values:** Points to the 'Minimum' and 'Maximum' columns in the Channel 1-7 table.
- Meter scale and scalar type:** Points to the 'Scalar' and 'Scalar Type' columns in the Channel 1-7 table.

Channel	Label	Unit	Minimum	Maximum	Scalar	Scalar Type	Norm zone
Channel 1	Final Votts	Votts	0	100	30	Scale (%)	Green
Channel 2	Final Amos	Amos	0	33	18	Scale (%)	Green
Channel 3	Output Power	Watts	0	50	10	Scale (%)	Green
Channel 4	Reflected PWR	Watts	0	40	10	Scale (%)	Green
Channel 5	Room Degrees	Degrees	0	100	1	Scale (%)	Green
Channel 6	Audio C-1	dB	-25	10	1	Scale (%)	Green
Channel 7	Audio C-2	dB	-25	10	1	Scale (%)	Green

The bottom fields are misc telemetry options:

- You can change the temperature reading from F to C.
- You can select auto-scale for the meters. When enabled, the meter max value will set itself as a function of where the meter pointer is (as a percentage of full scale) and what the value of the readings is.
- Hysteresis zones puts a splash of color on the meter face to indicate where the hysteresis zones are.
- The momentary action selects how the relay will respond if it is in latch mode. If set to toggle, a latched relay will unlatch momentarily, then re-latch. If set to Latch-> Unlatch, the relay will unlatch, then momentarily latch on for the duration specified in the delay box. The delay box specifies the maximum closure for any momentary action.

Setting static IP addresses and resetting the SiteSentry:

When you set a static IP address, your software and Web browser should automatically connect to the new IP address. You have 60 seconds to log in or else the unit will revert back to its previous IP address. **To force the change, unplug the power during the 60 second window.** The new address will be kept at power-up. If you set a static IP address that is not on your normal network mask, you could loose contact with the SiteSentry4. For example, if your network is configured to work in the range of 192.168.1.xxx and you inadvertently set your unit's static IP address to 192.168.0.xxx, then, on most networks, you will not be able to log into your SiteSentry4. Previously, there were only two solutions. One was to make a crossover cable and setup a computer to connect directly to the SiteSentry4 using the new network settings, but this only works if you didn't make a typo and therefore know the IP address of the unit. It's also a lot of work. The second solution was to reset your SiteSentry4 to factory defaults. This is easily done by shorting the internal pins marked "Reset" and toggling the power while maintaining the short. When the unit re-powers, it's back to defaults including obtaining a dynamic IP. We have added a step to this. Now when you reset your SiteSentry4, it will require two reset attempts if you have a static IP set. The first reset clears only the static IP flag and allows the unit to pick up a dynamic address. The second reset clears everything else.

Setting Alarm Points:

The SiteSentry4 uses a simple but flexible system for handling alarms. It can perform actions when conditions exceed upper or lower limits and it can perform actions when conditions return to normal, so it is possible to program a simple corrective action for one event and then to program another action to reverse the process when things return to normal. It has sixteen (16) event triggers (alarms) that can be programmed. Each trigger can respond to one of several possible conditions (upper alarms, lower alarms or status input changes). In order to activate a trigger, it is necessary to program the conditions that will cause the SiteSentry to trigger an action (sequence). Typically, these are lower or upper metering alarms, or status inputs. Lower and upper alarms are directly entered as a value (as opposed to a percentage of full meter scale as in earlier versions of the Sentry products). For instance, if you select an upper alarm of 900, the alarm will trigger whenever the scaled reading exceeds 900, but the trigger value must be on the meter's visible range. If the meter is from 0 to 5000 and a lower alarm is set to 1000, that will occur at 20% on the meter. At the point that the meter's value is reduced below the alarm threshold, the meter background will change to red or whatever color you have defined as the alarm color.

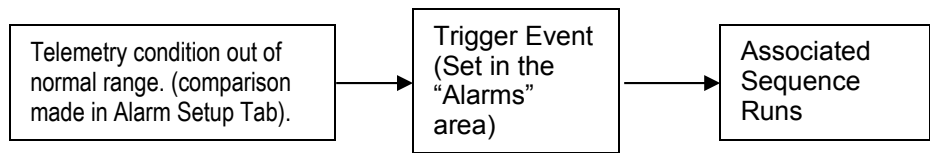

The Alarm setup box can be considered two forms in one.

The top half of the form is where you set the parameters that can trigger an event. It's also where you define the colors that will show up on your meter faces.

If you don't want alarms to show, just make them the same color as the meter's normal range. To disable an alarm, don't set a corresponding action. If you don't want to even see the tick marks for the alarm on the meter, just make the value of the alarm higher than the upper scale or lower than the lowest visible scale.

When setting lower alarm values, it's best to use some number other than zero because minor fluctuations of input signals can cause the meters to read greater than zero, especially if a large multiplier has been used in the telemetry scalar setting.

Parameter	Label	Value	ON delay	OFF delay	Critical zone	Warning zone
Final Volts	Lower Alarm	50.0	45	5	Red	Yellow
	Upper Alarm	90.0	45	5	Red	Yellow
Final Amps	Lower Alarm	30.0	45	5	Red	Red
	Upper Alarm	45.0	45	5	Red	Yellow
Output Power	Lower Alarm	3000.0	45	5	Red	Green
	Upper Alarm	4500.0	45	5	Red	Green
Reflected PWR	Lower Alarm	0.0	45	5	Green	Cyan
	Upper Alarm	35.0	45	5	Red	Yellow
Room Degrees	Lower Alarm	32.0	45	5	Red	Violet
	Upper Alarm	120.0	45	5	Red	Yellow
Audio Ch1	Lower Alarm	-40.0	45	5	Red	Silver
	Upper Alarm	6.0	45	5	Red	Yellow
Audio Ch2	Lower Alarm	-40.0	45	5	Red	Black
	Upper Alarm	6.0	45	5	Red	Yellow

The bottom half of the form is where you set the event that will trigger a user-defined sequence. There are 81 possible triggering events (in the non streaming version) that can control one of 16 available sequences. The actual sequences are defined on the Sequences tab.

Alarm #	Label	Event	Sequence
Alarm 1	Alarm #1	Disabled	Backup Aud ON
Alarm 2	Alarm #2	Upper Alarm OFF (CH2)	Backup Aud OFF
Alarm 3	Alarm #3	Upper Alarm OFF (CH3)	Sequence 3
Alarm 4	Alarm #4	Upper Alarm OFF (CH4)	Sequence 4
Alarm 5	Alarm #5	Upper Alarm OFF (CH5)	Sequence 5
Alarm 6	Alarm #6	Upper Alarm OFF (CH6)	Sequence 6
Alarm 7	Alarm #7	Upper Alarm OFF (CH7)	Sequence 7
Alarm 8	Alarm #8	Upper Alarm OFF AND Upper Alarm ON (CH3 NOT CH4)	Sequence 8
Alarm 9	Alarm #9	Upper Alarm OFF AND Upper Alarm ON (CH4 NOT CH3)	Sequence 9
Alarm 10	Alarm #10	Upper Alarm OFF AND Upper Alarm ON (CH6 AND CH7)	Sequence 10
Alarm 11	Alarm #11	Upper Alarm OFF AND Upper Alarm ON (CH2 NOT CH1)	Sequence 11
Alarm 12	Alarm #12	Upper Alarm OFF AND Upper Alarm ON (CH3 AND CH4)	Sequence 12
Alarm 13	Alarm #13	Input 1 ON (IN1)	Sequence 13
Alarm 14	Alarm #14	Input 2 ON (IN2)	Sequence 14
Alarm 15	Alarm #15	Disabled	Sequence 15
Alarm 16	Alarm #16	Disabled	Sequence 16

Event Triggers:

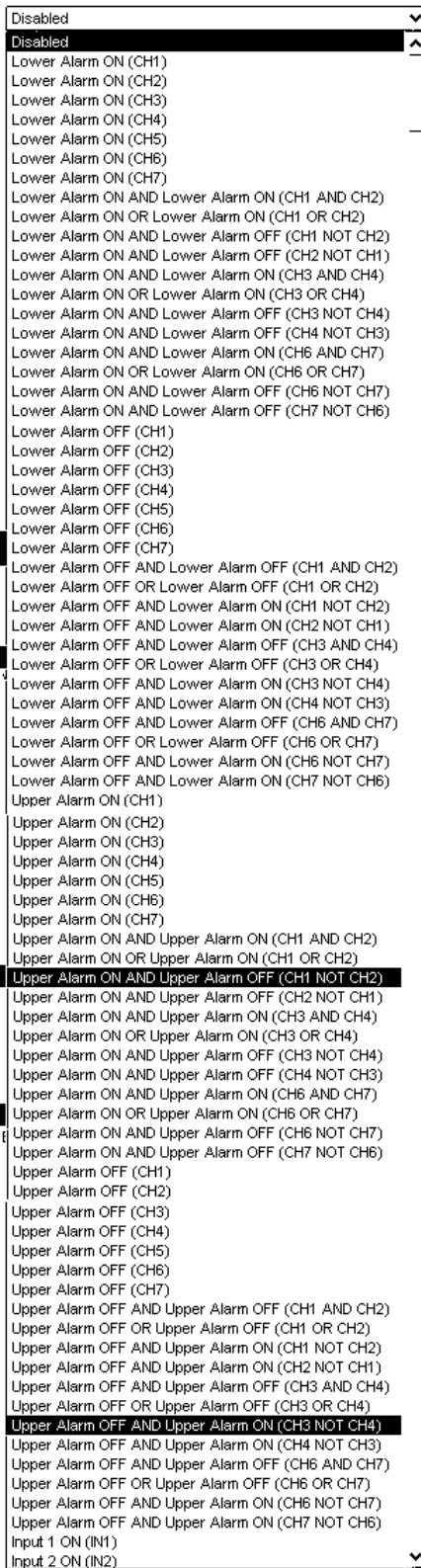

There are 81, non-streamng, events that can trigger actions.

Thirty-eight are permutations of low-meter conditions. You can react to low conditions on one or two channels, or you can react to the return of normal readings on those same channels. For multiple triggers, the channels may be grouped in pairs, Ch1 & CH2, Ch3/4 and Ch6/7 (Audio).

Similar to low meter detection, overload detection indicates when the input values are too high on a channel.

The four External “ON” events occur whenever one or both of the external status inputs are triggered, while the four External “OFF” events happen whenever the external status inputs are untriggered. Combinations include EITHER, BOTH or OR.

Each of these trigger events can be used to perform a different action. For instance, one alarm event (and action) might be if a low meter detection on channel 1 causes relay #1 to latch “ON”. A second event might then be used to unlatch relay #1 when low meter “OFF” (back to normal) condition is detected on channel one. By using two alarm events, you can create an automatic switchover system that will operate whenever a situation occurs and will automatically reverse itself whenever condition returns to normal.

Each channel’s upper and lower triggers are governed by their own set of timers, so you can choose how quickly the SiteSentry4 will respond to a particular condition. For instance, the Audio Silence detection might be set to occur after 30 seconds of silence on both channels (6 & 7), but you might want to know that the audio has returned after only 5 seconds, so that you can restore main programming. In that case, you would probably set an action sequence to occur on Silence OFF on either channel 6 or 7 and set both off delays to 5 seconds. Setting a timer to zero is an instant response.

Each “alarm” trigger can operate any one of the 16 available action Sequences

Sequences:

Telemetry Alarm Setup Notifications Connectivity Misc Streaming Sequences							
	Sequence Label	Action #1	Pause	Action #2	Pause	Action #3	Pause
Sequence 1	Backup Aud ON	Latch: Relay Relay 1	0	Turn ON FP LED Front Panel LED 2	0	Dispatch Email Receiver(s) Index 2	0
Sequence 2	Backup Aud OFF	Unlatch: Relay Relay 1	0	Turn OFF FP LED Front Panel LED 2	0	Dispatch Email Receiver(s) Index 2	0
Sequence 3	Sequence 3	No Action	0	No Action	0	No Action	0
Sequence 4	Sequence 4	No Action	0	No Action	0	No Action	0
Sequence 5	Sequence 5	No Action	0	No Action	0	Turn ON FP LED Turn OFF FP LED	0
Sequence 6	Sequence 6	No Action	0	No Action		Momentary: Relay Latch: Relay Unlatch: Relay	
Sequence 7	Sequence 7	No Action	0	No Action		Dispatch Email Mute Alarm	
Sequence 8	Sequence 8	No Action	0	No Action		Unmute Alarm Reset the Unit	
Sequence 9	Sequence 9	No Action	0	No Action		No Action	
Sequence 10	Sequence 10	No Action	0	No Action		No Action	
Sequence 11	Sequence 11	No Action	0	No Action		No Action	
Sequence 12	Sequence 12	No Action	0	No Action		No Action	
Sequence 13	Sequence 13	No Action	0	No Action		No Action	
Sequence 14	Sequence 14	No Action	0	No Action		No Action	
Sequence 15	Sequence 15	No Action	0	No Action		No Action	
Sequence 16	Sequence 16	No Action	0	No Action		No Action	

Save

Any trigger event can perform any of the 16 action sequences on the “sequences” list. There are thirteen basic (non-streaming) actions available and a sequence can run up to seven (formerly three) actions. Available actions include operating relays, either momentarily or latching, sending e-mails, turning on LEDs on the box, and muting or unmuting alarms (triggers).

When a latching action is performed, often a matching “unlatch” or “release” event is used to undo the action when the triggering event is over. For example, if audio is lost (silence ON), you might latch relays 1 and 2 “on” to act as a stereo, balanced audio switcher. When audio is restored (Silence OFF), you might unlatch relays 1 and 2 to switch back to regular programming. A similar function can be performed using a status input from an EAS decoder where the EAS message relay latches relay 2 to put the EAS on the air.

In addition to operating relays, the custom LEDs can be operated. The Custom LEDs are represented graphically on the Web server as gray (off) or green (on) lights. There are also two real LEDs on the front panel of the SiteSentry4 that can be operated by the same actions.

Each sequence can have up to three steps. There are programmable pauses available between steps as well. Using these, it is possible, for example, to have one event, close a relay, turn on one of the LEDs and then pause for a few seconds, then close, or open, another relay or send an e-mail.

Whenever actions are occurring, the SiteSentry4 will not respond to outside commands or to other events until the action has completed. If a pause is set to 60 seconds, then the SiteSentry4 will not be responsive to outside control, nor will it update its meters, until that time, plus whatever amount of time to run the action steps has passed.

Logging:

The SiteSentry4 can keep a log and can also e-mail it to you. Logging can be as simple or complex as desired. The log is a FIFO (First In, First Out) circular buffer. When the buffer is full, new entries push the oldest entries off the stack. The log can hold about 50 entries. Log entries can be by time or by action sequence, such as might occur in an alarm condition.

The output format of the logger is defined in the logging setup. The default format produces an easily read log but the format can be altered to read in any way desired by using the items from the drop down list. The log is divided into two parts, the header and the body. The header is printed at the beginning of the log and periodically throughout the log as defined by you in the first setup field. Any text that does not match a keyword is printed exactly as typed. For example, if you want meter one to print the value followed by the label "Amps", you would simply add the label after the meter value. If meter 1 is the Amp meter, then it would be entered as %mv1Amps instead of just %mv1. In other words, when you look at the default template, you will see that %mv1 is already there. You just type "Amps" between the %mv1 and %mv2.

The screenshot shows the 'Logging' configuration page for SiteSentry4 v1.0. The page includes a navigation menu with tabs for Telemetry, Alarm Setup, Notifications, Connectivity, Misc, Logging, Streaming, and Sequences. The Logging section contains several configuration fields:

- Print header every N entries; 0 disables header print:** Set to 20. Callout: "Defines how often to print the header within the log file."
- Last N log entries to email:** Set to 10. Callout: "Defines how many log entries to include with an e-mail"
- Log interval (in minutes); 0 disables timed logging:** Set to 180. Callout: "Defines how often to log a set of readings when time-based."
- Display log in reverse order (newest entry last):** Checked.
- Run sequence X every N entries; 0 disables this feature:** Set to Sequence 1 every 0 entries. Callout: "Lets you run a sequence based on how many log entries have happened. Be careful not to create a loop by having a logging command in the sequence that you use.."

Below these fields are two template sections:

- Log header template:** Shows a table with columns for Date/Time, Channels, Inputs, and Relays. Below the table is an 'Insert' dropdown set to 'Year (%dy)' and a 'Save Log Header Template' button.
- Log entry template:** Shows a text area with a default format: | %dy-%dm-%dd %th:%tm:%ts | %mv1 %mv2 %mv3 %mv4 %mv5 %mv6 %mv7 | %sv1%sv2 | %rv1%rv2. Below the text area is another 'Insert' dropdown set to 'Year (%dy)' and a 'Save Log Entry Template' button.

At the bottom of the page, there is a callout box: "The bottom half of the form is where you define the format of the log".

CircuitWerkes Site Sentry 4 Web Interface v1.0, Web Server Firmware v1.0
©Copyright 2012, CircuitWerkes, Inc.
Best viewed on IE7+, Chrome, Firefox 6+ in 1024x768+ resolution

An example of a modified logging setup.:

The default header looks like this:

```
| Date/Time | Channels | Inputs | Relays |
```

In order to get the output below, the following header was created:

```
| Date/Time | Channels | Inputs | Relays |
| 1 2 3 4 Temp Aud1 Aud2 | 1 2 | 123456 |
```

Zero (0) is "Off" and one (1) is "On".

The result is below....

	Date/Time	Channels						Inputs		Relays						
		1	2	3	4	Temp	Aud1	Aud2	1	2	1	2	3	4	5	6
T	12-09-13 14:12:57	0.000	0.000	0.000	4.940	77.000	-4.696	-7.933	00		000000					
T	12-09-13 14:13:57	0.000	0.000	0.000	4.940	77.000	-10.912	-10.525	00		000000					
T	12-09-13 14:14:57	0.000	0.000	0.000	4.940	77.000	-12.655	0.081	00		000000					
T	12-09-13 14:15:57	0.000	0.000	0.000	4.987	77.000	-14.837	-6.396	00		000000					
T	12-09-13 14:16:57	0.000	0.000	0.000	4.940	77.000	-2.491	-4.891	00		000000					
T	12-09-13 14:17:57	0.000	0.000	0.000	4.940	77.000	-5.091	-3.112	00		000000					
T	12-09-13 14:18:57	0.000	0.000	0.000	4.940	77.000	-9.461	-12.655	00		000000					
T	12-09-13 14:19:57	0.000	0.000	0.000	4.940	77.000	-6.396	-7.933	00		000000					
T	12-09-13 14:20:57	0.000	0.000	0.000	4.940	77.000	-4.135	-4.891	00		000000					
T	12-09-13 14:21:57	0.000	0.000	0.000	4.940	77.000	-4.891	-2.343	00		000000					
T	12-09-13 14:22:57	0.000	0.000	0.000	4.940	77.000	-12.655	-12.185	00		000000					
T	12-09-13 14:23:57	0.000	0.000	0.000	4.940	77.000	-6.396	-5.295	00		000000					
T	12-09-13 14:24:57	0.000	0.000	0.000	4.940	77.000	-5.295	-22.197	00		000000					
T	12-09-13 14:25:57	0.000	0.000	0.000	4.940	77.000	-8.817	-10.525	00		000000					
T	12-09-13 14:26:57	0.000	0.000	0.000	4.940	77.000	-6.396	-8.512	00		000000					
T	12-09-13 14:27:57	0.000	0.000	0.000	4.940	77.000	-7.657	-9.801	00		000000					
T	12-09-13 14:28:57	0.000	0.000	0.000	4.940	77.000	-15.481	-14.837	00		000000					
T	12-09-13 14:29:57	0.000	0.000	0.000	4.940	75.755	-3.781	-12.185	00		000000					
T	12-09-13 14:30:57	0.000	0.000	0.000	4.987	75.755	-8.817	-4.696	00		000000					
T	12-09-13 14:31:57	0.000	0.000	0.000	4.940	75.755	-6.164	-5.719	00		000000					
	Date/Time	Channels						Inputs		Relays						
		1	2	3	4	Temp	Aud1	Aud2	1	2	1	2	3	4	5	6
T	12-09-13 14:32:57	0.000	0.000	0.000	4.940	77.000	-19.698	-25.719	00		000000					
T	12-09-13 14:33:57	0.000	0.000	0.000	4.940	75.755	-13.151	-5.719	00		000000					
T	12-09-13 14:34:57	0.000	0.000	0.000	4.987	75.755	-0.858	-4.891	00		000000					

The first character is either a T for time triggered or a sequence number (like S13) to indicate what caused the log reading to be taken.

E-mail notifications Setup

telemetry	Alarm Setup	Notifications	Connectivity	Misc	Logging	Sequences	Time
-----------	-------------	---------------	--------------	------	---------	-----------	------

SMTP Server settings:	
Server:	<input type="text" value="relay.appriver.com"/>
Port:	<input type="text" value="2525"/>
Username:	<input type="text"/>
Password:	<input type="password"/> <input type="button" value="Submit"/>
From:	<input type="text" value="Use a valid email address here!"/>
Append logs to emails as	<input type="text"/>
Message: [0] Ready.	
<input type="button" value="Save"/>	

Recipient list (80 characters max per group):	
Recipient(s) group #1:	<input type="text" value="You can use more than 1 address per line with a comma seperator"/> <input type="button" value="Test Email"/>
Recipient(s) group #2:	<input type="text" value="For Texts, use 10 digit phone numebr with carrier's e-mail-to-text gateway"/> <input type="button" value="Test Email"/>
Recipient(s) group #3:	<input type="text"/> <input type="button" value="Test Email"/>
Recipient(s) group #4:	<input type="text"/> <input type="button" value="Test Email"/>
Recipient(s) group #5:	<input type="text"/> <input type="button" value="Test Email"/>
<input type="button" value="Save"/>	

E-mail notifications can be sent to you for alarm purposes as part of your sequences. In order to send mail, you must use a mail server that does not require SSL/TLS secure access (**in other words, no gmail.com**). Most unsecured mail servers will use port 25 or 2525 or 1025. If your server requires port 995 or 465 or 587, it's probably not going to work. In addition to being open, the mail server must support standard SMTP.

For mail servers that require a user name and password, there are fields provided to enter the required information.

The "From" field should normally contain a valid reply to address. Some mail servers will not deliver mail unless there is a valid reply to address.

The "Subject" field is the title that will be prepended to each e-mail's subject line.

The bottom half of the form has five fields for entering e-mail addresses. **Each field can contain more than one address, separated by a comma for each.**

SMS texts are actually just e-mails sent to the target mobile number at the carrier's SMS domain name. For example, 987-654-3210@txt.att.net (no dashes would be entered in the phone number, of course).

Connectivity (Network settings):

The SiteSentry allows you to change almost everything about the network configuration.

The HTTP port is typically 80, but you can change it to anything that you want.

The MAC address is unique to each unit and is not user changeable, however, it is possible for the factory to alter your unit's MAC address in the field using a special utility. We must have direct access to your unit to change the MAC address.

Current Remote IP	74.179.113.182
Current Local IP	192.168.0.154
HTTP Port	80
MAC Address	00:04:A3:00:00:01
NETBIOS Hostname	SITESENTRY4
Static IP (0.0.0.0 = not used/DHCP enabled)	0.0.0.0
Subnet Mask	255.255.254.0
Default gateway	192.168.0.1
Primary DNS server	192.168.0.1
Secondary DNS server	0.0.0.0

The Netbios Name is optional and allows you to find computers or devices by name instead of knowing their IP address. When you call a Netbios name, a request is sent across the network for a response from any device with the matching name. If that device has a Webserver, it can be loaded into your browser directly without calling the IP address, much like a domain name works over the Internet.

When calling a device by its NetBios name, it should be entered complete with the http:// preceding the device name. For example entering <http://sitesentry4/> into the address bar will work whereas just sitesentry4/ won't. Also, Android does not support NetBios calls, so you have to know the IP address of the product when browsing in using Android devices.

The SiteSentry is normally configured for DHCP by setting the four address octets to 0.0.0.0. If you want to enter a static IP address, you can direct enter it in the Static IP field as ###.###.###.###.

When set to DHCP, the SiteSentry will detect the default gateway and enter its address in the "Default Gateway" field and also in the "Primary DNS Server" field. When a static IP is set, you can alter the gateway and DNS fields manually.

Differentiating multiple devices on a common network:

The SiteSentry4 has a fixed, unique MAC address but allows you to change the IP address and Netbios name of the device. These can be important when multiple CircuitWerkes Webserver based products are used at a common location. In that case, you will want to assign a unique Netbios name to each device so that each device can be found by a unique name. If using static IP addresses, you will need to set a unique one for each device.

Dynamic DNS:

A dynamic DNS service (DDNS) allows you to operate devices requiring a static address on networks that have only dynamic IP addresses. You make up a name for your location and register it with a DDNS service.

Whenever your IP address changes, the device detects the change and notifies the host DNS service. The host service then modifies the address that the name points to. So when you try to login using the name, it always points to the right address. Currently the SiteSentry supports dyndns.org, no-ip.com and dnsomatic.com. All of these services offer free and paid services. Other services also may work with your particular dynamic update service, but you will have to try yours and see if it works. Type the network name of your service (service_name.com) into the blank box and fill in the rest of the form. After setting up an account, enter your credentials into the fields of the DNS settings page and save them. DDNS has been tested, but is considered a beta feature.

DDNS Service:	members.dyndns.org
Username:	
Password:	
Host:	
Status:	undefined

Save DDNS Settings

Passwords and system utilities:

In the MISC tab you can change access codes for the three classes of users. Administrators can configure and control the SiteSentry. Controllers cannot configure the device, but can operate its controls. Readers can only see the main page and cannot operate any relays.

Timed sequences let you perform actions based on elapsed time. Using these you can perform a task every hour, every 24 hours or every 168 hours (week).

The resets/reboot section lets you restart your SiteSentry or load default values. The connectivity button changes the MAC address, Netbios name, IP port number and IP address back to defaults, but leaves the main configuration data intact. The bottom button overwrites everything with default data. This is a requirement when upgrading the firmware.

Saving Your Unit's Configuration Data to Your PC:

The import/Export functions are VERY important. This function lets you save your configuration data to a local file. You can also load saved data into a virgin SiteSentry without having to program everything from scratch. When you click the “Export” button, you will be presented with a text box containing a lot of information. Select the entire contents of the box (CTRL-A in Windows). Copy the entire contents to the clipboard (CTRL-C). Then open up a text writer like notepad and paste everything into it (CTRL-V). Save the new file. DO NOT MODIFY THE CONTENTS OF THESE FILES.

To import saved data, open the text file that you previously saved and copy everything to the clipboard (CTRL-A, then CTRL-C). Then click the “Import” button and paste the contents of the clipboard to it and click the “Import” button on this form. When done importing, click the “Save” button at the bottom of the main form, or click any of the save buttons on any of the other tabs. Note that network settings are not automatically saved because they would cause the unit to potentially change IP addresses in the middle of the process and you might not find it if you don't know what IP address and range it is using. Therefore, you have to make those changes individually.

Note that the configuration page lets you export and import settings from your browser. On some computers, the import/export function may only work properly with Internet Explorer.

Optional Streaming

The SiteSentry series offers an optional hardware upgrade that lets you receive Shoutcast compatible mp3 or Ogg-Vorbis streams. Receiving audio can be used as a backup audio source for routing the air. The optional streaming module also lets you encode (transmit) Ogg-Vorbis streams in stereo or mono at various bitrates. Encoded streams are useful as confidence audio, letting you verify that your audio is reaching the transmitter site properly. The Ogg-Vorbis streams are of very high quality, rivaling AAC at medium & high bitrates. The encoded streams can be received on many media players including VLC, Foobar 2000, and WinAmp (with the Ogg plugin). Transmit audio, although high quality, is only intended for confidence monitoring, not as a point-to-point streaming source for critical applications. Due to a small transmit buffer size only one client can be connected at a time and dropouts can occur periodically in the encoded stream.

The streaming setup controls will only be enabled if the streaming hardware is present. When no streaming hardware is present, the streaming tab will only have a notice that streaming is not available on this version. The streaming module information will also not appear on the main metering page.

Transmit Audio Mode:

In the transmit mode, the main metering page shows you the mode (Transmit), the status (ready or occupied) and the IP address of the remote client, if any. There is a button labeled “kick”. If there is a remote client connected to your stream that you don’t want, you can use the “kick” button to disconnect them. The “Socket Ready” text tells you no one is currently connected. When a remote client is connected, their IP address is displayed and the simulated LED will be green.

Local IP	192.168.0.128
NetBIOS	SITESENTRY4
Front Panel:	
<input type="radio"/>	Front LED 1
<input type="radio"/>	Front LED 2
Inputs:	
<input checked="" type="checkbox"/>	Input 1
<input checked="" type="checkbox"/>	Input 2
Audio Mode: Transmitter	
192.168.0.128:8000	
<input type="radio"/>	Socket Ready
	Kick

Transmit Audio Setup

- Voice 8kHz Mono Low Quality
- Voice 8kHz Mono High Quality
- Voice 16kHz Mono Quality
- Voice 16kHz Stereo Quality
- HIFI Voice 44.1kHz Mono Low Quality
- HIFI Voice 44.1kHz Mono Medium Quality
- HIFI Voice 44.1kHz Mono High Quality
- Music 44.1kHz Stereo Low Quality
- Music 44.1kHz Stereo Medium Quality**

Above: Transmit Quality Settings

The transmit mode has two main settings groups that you can change. First is the quality mode. You can choose from CD quality stereo, through several low bitrate medium quality stereo or mono settings. Very low (voice only) quality settings are available for networks with extremely limited bandwidth. The second main settings group are the auto-gain settings. The encoder uses an optional DSP based AGC & peak limiter to maintain optimum encode amplitude. The AGC/limiter is optional and can be disabled by un-checking the “AutoGain” box. The AGC has a setting that limits the maximum gain to avoid pumping and noise pickup during low passages. In order to avoid pumping and sucking up of noise, we suggest setting the AGC limit to four or less and use the audio drive controls to feed a high level to the encoder.

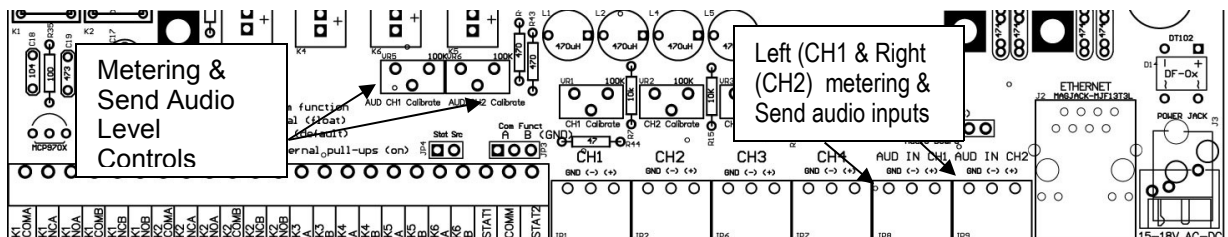

Receive Audio Mode:

In the receive mode, the SiteSentry can decode Ogg-Vorbis or mp3 shoutcast compatible streams. When in the receive mode, the Audio module on the main page will display the connection information along with buttons to connect or disconnect. If enabled in setup, sliders for adjusting the output gain will be present as well.

Receive Audio Setup

When set to receive mode, you can set up to five receive stations. Each of these stations consists of the IP address and port number of the streaming audio. The five streaming sources form a “hunt” group, meaning that if the stream from one fails, the decoder can be set to move down the list to the next. Each streaming source can be individually enabled. If not enabled, that stream will not be included in the hunt group. Each index of the hunt group can be named for easy recognition. Below the hunt group are the five indexes as radio buttons. Here you can select which will be active (the main stream).

Persistent decoder connect and retry attempts: When persistent decoding is enabled, the SiteSentry will try each index the user defined number of retries before moving on to the next. When the last index is reached, the loop will start over until a connection is achieved.

Treble and Bass controls: These DSP based controls are built-in to the decoder hardware. You can adjust the knee frequencies and the amount of boost for each. These controls only work at lower audio output levels (below -15dB for full effect). Because operating the decoder output at a lower level can result in increased noise (due to the low level needing to be amplified more downstream), you should decide if the advantages of using the tone controls is worth any noise penalty that you might face. Note: The treble controls are not enabled on this version, however bass is.

You can also set the delay before registering the loss of streaming as an alarm. The stream alarm resets whenever a stream is successfully started, even if it is not the primary.

The variable playback box is only used for some obscure Ogg-Vorbis streams and should not be used 99.99% of the time.

Receive Audio hardware:

SiteSentry4's with the streaming option also have an audio output daughter board installed that amplifies the received audio stream and gives you an active, balanced, output from the streaming engine.

GND	(-)	(+)
Streaming Audio Output Connectors		

26

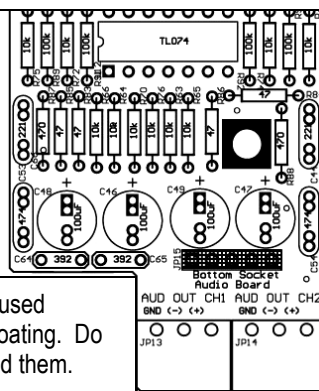

Leave unused outputs floating. Do not ground them.

Date & Time:

All versions of the Sentry products, have the ability to calibrate their clocks to an NTP (Time) server. They will keep time if an NTP server is not available, but there are two caveats:

1. They will not keep time if power is interrupted. When power returns, they will attempt to sync the clock with NTP if available.
2. The clock function in the 8-bit product is a timing loop which will not be very accurate. Expect drift of 1 to 5 minutes per hour if no NTP server is available. The 32 bit streaming versions use a clock crystal to keep better time.

The 8-bit version of the product does not include a scheduler, but it can run up to three sequences on a repeating schedule, so you can do things like mute tower light alarms at dawn and unmute the alarm at dusk. You can also email logs to yourself at specified intervals instead of per number of log entries. Setup for these sequences can be found in the "misc" tab as described above.

The time setup box lets you set the current time and also selects how often to automatically sync the SiteSentry clock to an NTP server. The NTP server list is embedded in the stack and is not currently user adjustable. In the 8-bit version of the product, time is currently used to time-stamp log entries, but may be used for other processes in the future. Setting NTP update to zero disables updating. You can also manually sync the Sentry's clock to your PC, if desired.

The screenshot shows a navigation bar with tabs: Telemetry, Alarm Setup, Notifications, Connectivity, Misc, Logging, Sequences, and Time. The Time tab is selected. Below the navigation bar is a form for configuring the time settings. The form includes a 'Sync with PC' button, a date/time input field (MM-DD-YY HH:MM:SS), an NTP Server input field (pool.ntp.org), an NTP Port input field (123), an NTP Update Interval input field (10), and a GMT Offset input field (-300). A 'Save' button is located at the bottom right of the form.

Field	Value
MM-DD-YY HH:MM:SS	
NTP Server	pool.ntp.org
NTP Port	123
NTP Update Interval (in minutes); 0 disables NTP	10
GMT Offset (in minutes)	-300

Event Scheduler:

The 32 bit version of the SiteSentry4 contains a basic event scheduler with 50 events. This scheduler can be used to automate AM pattern and power changes. The granularity of time resolution is + or - 600ms, so it can be used to pre-roll audio cuts or switch transponders at appropriate intervals prior to taking a program. The event scheduler can be programmed to run once, repeat constantly, or repeat for a specific duration (such as a month). Repeating events that end can be programmed to repeat during the next year so that AM changes can repeat themselves every year during the same month.

The events are triggered by the onboard clock. The clock can be setup to observe daylight savings time (DST), but if DST is used, any AM change schedules will need to be manually adjusted to compensate for the 1 hour difference. The onboard clock syncs itself to time servers but will continue to keep time if the network is disconnected. However, if the power is disconnected, the clock will stop and hold at the most recently stored second. When power is re-applied, the RTC will begin counting again and, if there is a network time server available, the SiteSentry4 will self-sync its clock within a few minutes.

The screenshot shows the 'Time & Events' configuration page in SiteSentry4 v1.5.3. The interface is divided into several sections:

- Events Summary:** A table with columns for 'active', 'expired', and 'disabled' events. Each event is represented by a date-time string (e.g., '1 0 01-01-12 00:00:00'). A callout box points to a row with the text 'Event is disabled'.
- Selected Event Information:** A table showing details for a selected event, including 'Expired', 'Next occurrence', and 'Occurrence count', all currently showing 'N/A'.
- Selected Event Setup:** A form for configuring an event. It includes options for 'Enable Event' (checked), 'On event trigger sequence' (Sequence 1), 'Entry Type' (One Time or Recurring), 'Start Date/Time' (01-01-12 07:00:00), 'Recurrence Type' (Minutes, Hours, Days, Weeks, Months, Years), 'Recurrence Interval' (1), 'Exit Type' (None, Date, Occurrences), 'End by' (01-31-12 23:59:55), and 'Repeat Annually' (checked). A callout box explains that this setup is for an AM power change that repeats every year.
- Set date/time stamp manually:** A section for manual clock synchronization, including fields for 'MM-DD-YY HH:MM:SS', 'NTP Server', 'NTP Port', 'NTP Update Interval (in minutes)', 'GMT Offset (in minutes)', and 'Enable daylight saving time (DST/ST)'. A callout box explains that these settings allow syncing the clock to a PC, setting the NTP server, DST options, and time zone.

Firmware upgrades

The SiteSentry can be field upgraded when new features are added or when bugs are corrected. A special password protected Webpage is the gateway to upgrading. After upgrading, you must always reset your unit to factory defaults, so **be sure that you have saved your configuration data before starting** the upgrade process.

Note that the streaming versions of the SiteSentry units use a 32 bit processor core while the non-streaming versions use an 8-bit core. The firmware loader tool and firmware files are different for each processor.

Step 1. You must download or have the CircuitWerkes firmware loader tool from our Website. You must also have the firmware files for your product. The firmware files are typically zipped up together in one file. It's OK if the version numbers don't match as long as the two files are from our original zip file.

The firmware loader utility is the same for all SentryX products, including the WAM-2. The only difference is if the core is 32bit or 8 bit as described above.

You do not need to download multiple copies of the loader tool. Install the firmware loader tool on your PC.

Specific 8-bit instructions:

Step 2. Run the FW loader tool and select the DFF (8bit) file that you downloaded for your product.

Step 3. Set the IP address of your product in the loader tool and upload the DFF file to your unit.

Specific 32bit instructions:

Step 2. Run the FW loader tool and put the IP address of your unit into the loader. Press the connect button and, if successful, you should see the bootloader version number displayed.

Step 3. Browse for and select the .HEX file that you downloaded for your product using the "Load Firmware" button and upload the .HEX file to your unit using the "Flash Firmware" button.

All units:

Step 4. Using a browser, log into `###.###.###.###/imageflash`

If you're using a port other than 80, it would look like this: `###.###.###.###:PORT#/imageflash`

Step 5. Login as Admin and use the administrator code that you have set. Default = 12345678.

Step 6. Click the "choose" button and browse to find the .BIN file that you will be uploading.

Step 7. Click "Upload" to send the new BIN to the product.

Step 8. Reset your product to factory defaults. If using the hardware reset, do it at least 2x. Each time you reset the unit, wait, with power applied, for 10 seconds before removing power for the next reset. The hardware reset is done by removing the top cover and shorting the reset pins while powering up the board. Reset pins are found near the front panel LEDs.

Step 9. Import/Upload your configuration data back to the unit and save the changes. Note that connectivity settings and passwords have to be done manually, one at a time.

Note: If you have trouble, reboot the product. During the 1st 5 seconds, the unit will assume a default IP address of 192.168.0.200. If you reboot the unit and immediately push the connect button, you may be able to connect on that node, even if it is outside of your routers netmask. After the first few seconds, the unit will return to its previous IP address or a DHCP address.

Specifications

Dimensions	1.75" H x 8.5" W x 6" D 1RU rack-shelf-mountable
Weight	approx. 3 lbs.
Power	15Vdc @ 200mA supplied by included 117VAC @ 60 Hz wall adaptor
Relays	4 SPDT relays rated at 10va @ 15 VDC. 2 DPDT relays rated at 1 A @ 30 VDC, 0.3 A @ 125 VAC for 5 x 10 ⁵ cycles



CAUTION: While the SiteSentry's DPDT relays can handle 120 VAC, this practice is very dangerous and is strongly discouraged by CircuitWerkes. Switching of hazardous voltages should only be done in a manner that isolates the voltages from accidental contact with people. Never switch lethal voltages directly with the SiteSentry! **Not Ever.**

Metering Inputs - 4 DC site inputs in 3.5mm depluggable screw terminals capable of accepting 0 to 10V with reference to ground. Negative voltages can be measured via the (-) metering inputs.

Audio Inputs - Balanced stereo input on the SiteSentry4 or unbalanced on the SS4-LE. Can detect silence or overload.

Temperature sensor - Displays ambient temperature at the back panel of the PCB. Configurable for F or C. Low and High temp alarms.

Status Inputs - 2 contact-closure inputs. Pull to ground to activate or supply your own voltage (jumper configured).

Ethernet - Internal Web server with DHCP or static IP capability. Browser must have Javascript.

Relay outputs - Six total relays on board. Two are DPDT with contacts rated at 1amp. The remainder are SPST with contacts rated at 10VA (100ma MAX NON-Inductive). All relays can be momentary or latching

Alarms - 16 onboard alarms can respond to 81 possible conditions, each. Responses can consist of single or up to 3 actions, performed in sequence, with user defined pauses. A list of available actions lets the user define which actions can be taken for a given alarm.

Notifications - The onboard e-mailing function can send e-mails or SMS messages when alarm conditions are present. In future release of multisite software, you will be able to trigger notifications if any of the sites enter alarm. For secured mail servers, the software will have an option to use the default mailer program, such as Outlook Express, to send the notifications.

Logging - A simple log is kept and updated at a user defined interval (default 3hrs). The log can be downloaded via the Webserver. Each log entry is time and date stamped. Time and date are kept updated by an internal pool of NTP servers. If NTP is not available, the clock can be manually set and the clock will continue to operate without NTP.

Audio Streaming - Send audio (encode mode) produces an Ogg-Vorbis output with various quality settings and sample rates ranging from 8kHz mono to 44.1kHz stereo. Maximum quality output is approximately 135kbs which yealds a 20Hz to 18kHz audio sample. Minimum quality is approximately 9kbs which results in a 3.5kHz audio sample. The encoded streams are Shoutcast/Icecast compatible. Ogg streams are not interoperable with many dedicated streaming decoders, but are, generally receivable on most computers including tablets. Most Windows based browsers, except Internet Explorer, will play the streams directly in the browser. The audio stream from the Sentry can be of high quality but is not intended to be used for continuous point to point communications, such as an Internet STL. Occasional pops and skips may be encountered due to timing limitations of Ogg data streams. Also, the Webserver may be sluggish while the device is encoding data at high sample rates.

The Sentry will decode most Shoutcast./Icecast compatible streams if they are encoded in either mp3 or Ogg format. The frequency response of the audio is 20Hz to 17kHz, depending upon the encoded stream settings. The Sentry's receive audio can be routed through the DPDT relays as an emergency backup STL, but it is not intended to be a permanent STL. Direct connection to other companies' streaming encoders is not guaranteed or supported. Do so at your own risk.

SiteSentry4 Schematic. Note the SiteSentry4-LE is similar but lacks the balanced audio input/output.

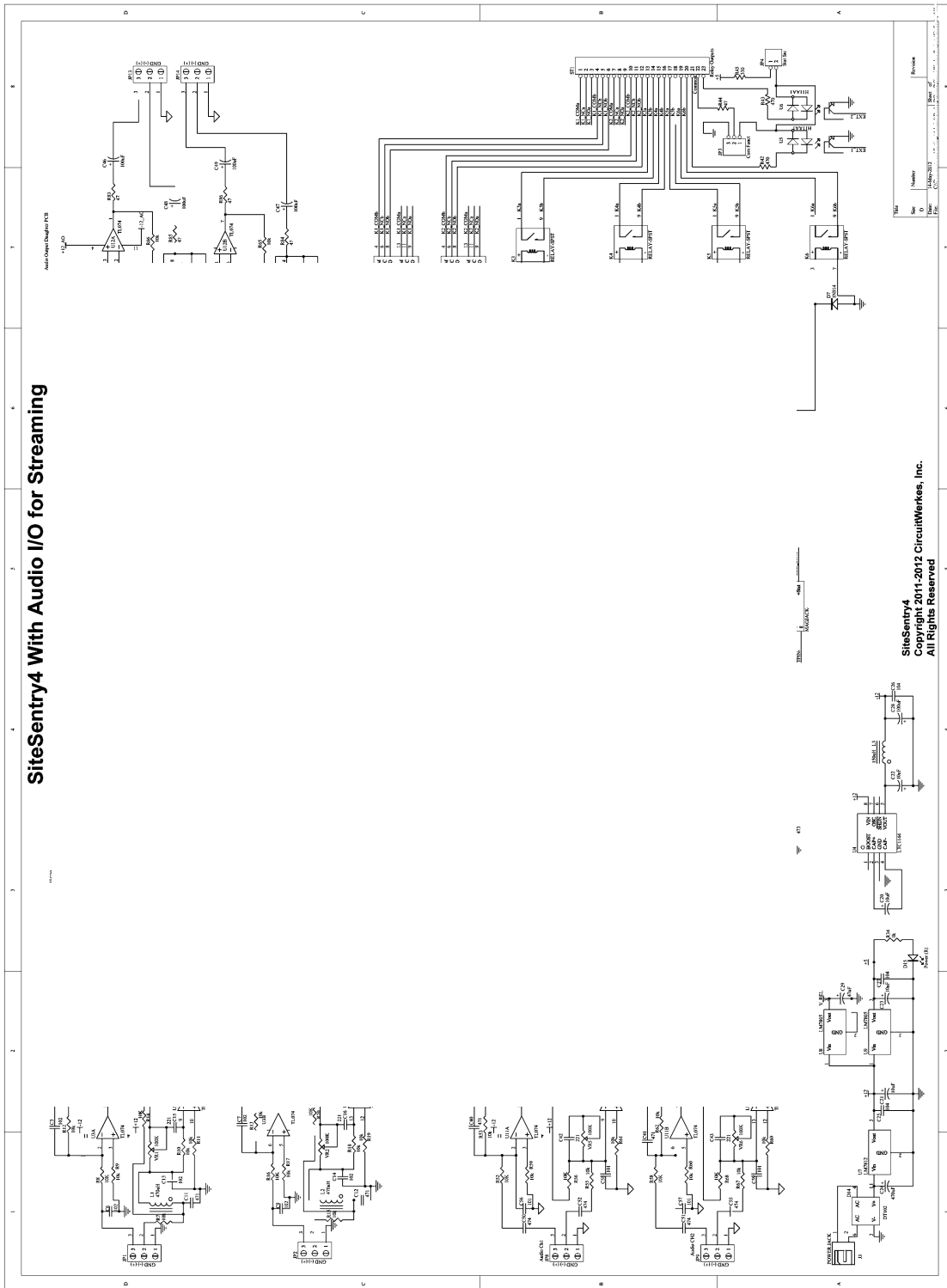

Warranty

CircuitWerkes, Inc. (Manufacturer) warrants that this product is free of defects in both materials and workmanship. Should any part of this equipment be defective, Manufacturer agrees, at its option, to:

- A. Repair or replace any defective part free of charge (except transportation charges) for a period of two years from the date of the original purchase, provided the owner returns the equipment to the Manufacturer at the address set forth below or stated at time of RMA issue from Manufacturer. No charge will be made for parts or labor during this period:
- B. Furnish replacement for any defective parts in the equipment for a period of two years from the date of original purchase. Replacement parts shall be furnished without charge, except labor and transportation.

This warranty excludes assembled products not manufactured by Manufacturer whether or not they are incorporated in a Manufacturer product or sold under a Manufacturer part or model number.

THIS WARRANTY IS VOID IF:

- A. The equipment has been damaged by negligence, accident, act-of-God or mishandling, or has not been operated in accordance with the procedures described in the operating and technical instructions; or,
- B. The equipment has been altered or repaired by other than Manufacturer or authorized service representative of Manufacturer; or,
- C. Adaptations or accessories other than those manufactured or provided by Manufacturer have been made or attached to the equipment which, in the determination of Manufacturer, shall have affected the performance, safety or reliability of the equipment; or,
- D. The equipment's original serial number (if applicable) has been modified or removed.

NO OTHER WARRANTY, EXPRESS OR IMPLIED, INCLUDING WARRANTY OF MERCHANTABILITY OR FITNESS FOR ANY PARTICULAR USE, APPLIES TO THE EQUIPMENT, nor is any person or company authorized to assume any warranty for Manufacturer or any other liability in connection with the sale of Manufacturer's products.

Manufacturer does not assume any responsibility for consequential damages, expenses or loss of revenue or property, inconvenience or interruption in operation experienced by the customer due to malfunction in the purchased equipment. No warranty service performed on any product shall extend the applicable warranty period.

In case of unsatisfactory operation, the purchaser shall promptly notify Manufacturer at the address set forth below in writing, giving full particulars as to the defects or unsatisfactory operation. Upon receipt of such notice, manufacturer will give instructions respecting the shipment of the equipment, or such other matters as it elects to honor this warranty as above provided. This warranty does not cover damage to the equipment during shipping and Manufacturer assumes no responsibility for such damage. All shipping costs shall be paid by the customer.

Repair or Service Information

In the event of the need for service or repair, call CircuitWerkes at (352) 335-6555 for a Return Merchandise Authorization number (RMA). Then carefully package the unit along with a note of the problem and send it to the address below. Be sure to include your contact information (address - not PO Box - telephone numbers) and best time to call.

This warranty extends only to the original purchaser and is not assign-able or transferable.

CircuitWerkes • 2805 NW 6th Street • Gainesville, FL 32609
Voice 352.335.6555 • Fax 352.380.0230 • info@circuitwerkes.com • www.circuitwerkes.com